

ENVISION

Imagine • Conceive • Design • Dream

Envision
your new laboratory.

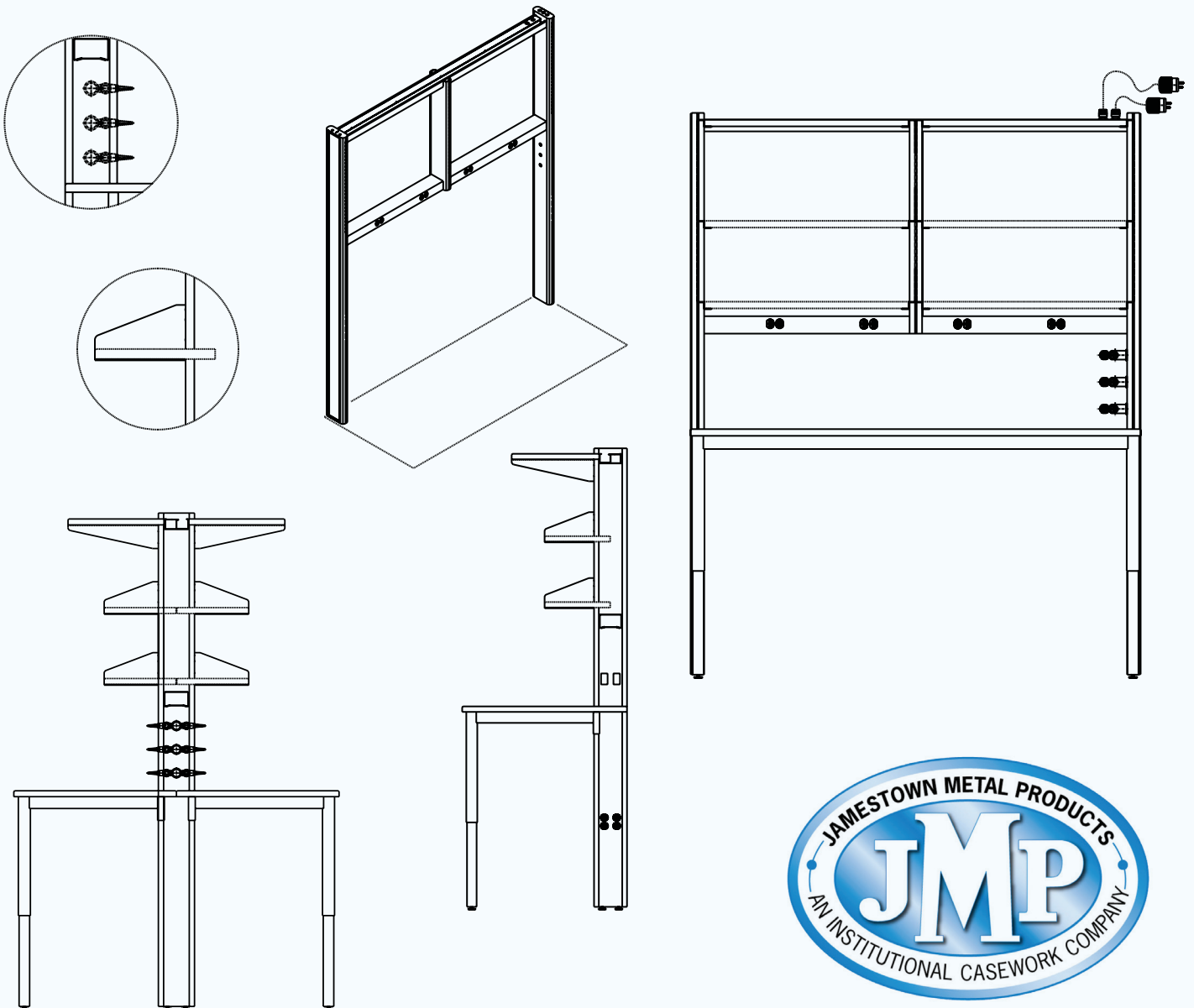

ENVISION the work bench assembly for your laboratory's specific needs, then follow these selection steps to fulfil your workbench vision. ENVISION is uniquely designed to link to most existing work benches with flawless compatibility.

1. *Select the upright.*
2. *Select the frames, one for a single workbench; or, two for a double workbench.*
3. *Select the counter top: one for a single frame, two for double frame.*
4. *Select plumbing. Plumbing is ordered separately, single fixtures for single frame; double fixture for double frame benches. ENVISION offers broad variety of fixture options with a broad scope of services.*
5. *Select from a broad selection of pre-wired, electrical service options.*
6. *Select one (1) book-end shelving unit and one (1) inverted shelving unit per frame for 42" and 48" wide frames; and, two (2) book-end shelving units and two (2) inverted shelving units per frame for frames that are 60", 72", 84" and 96" wide.*
When ordering shelves for double workbenches, select two (2) book-end shelving units and two (2) inverted shelving units per frame for 42" and 48" wide frames; and, four (4) bookend-shelf units and four (4) inverted shelving units per frame for frames that are 60", 72", 84" and 96" wide.
7. *Select, if needed, one mobile cabinet stop per frame.*

ENVISION SINGLE WORK BENCH

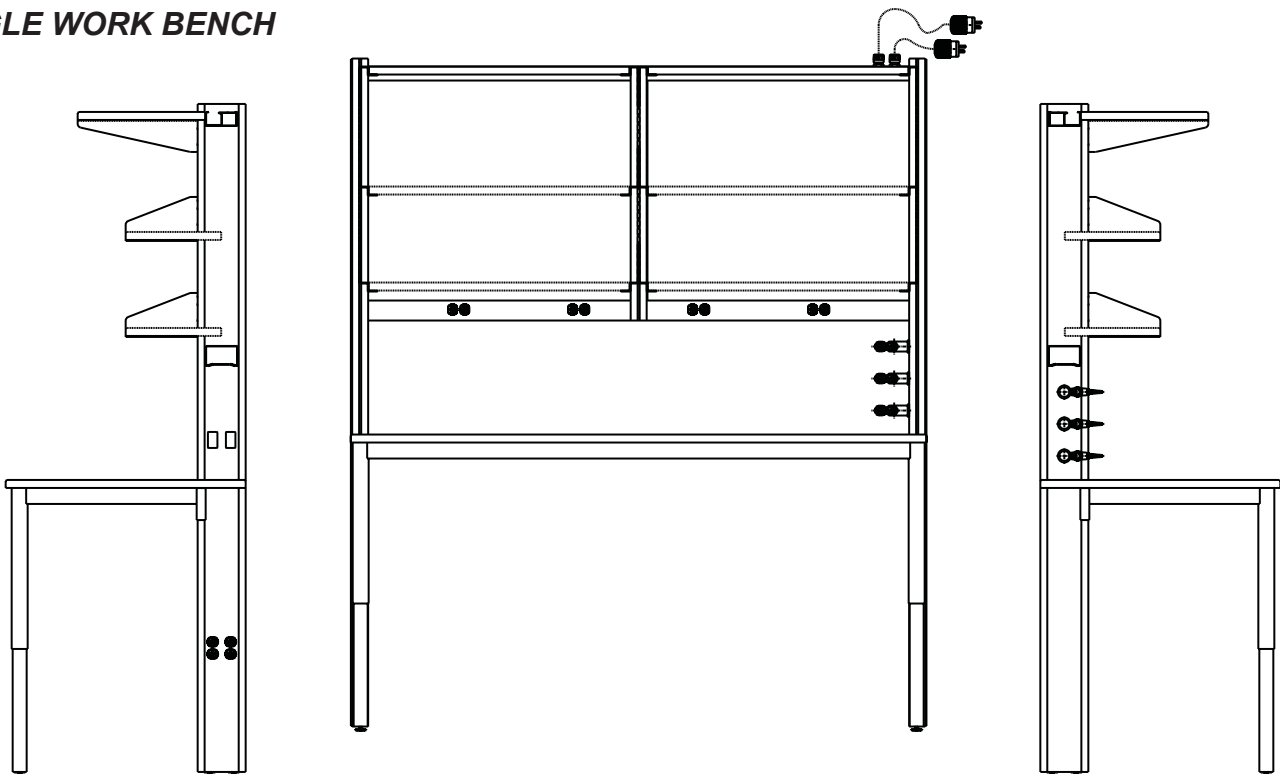

Envision work benches are 84" high overall. Shelf units have a 29" adjust area, and countertops are adjustable to 30", 32", 34", 36" and 37" heights. There are no center support uprights on 42" or 48" wide frames, shelves on those units are full width. Units over 48" wide are equipped with a center vertical column to add stability to the cross rail. Uprights and frame legs are equipped with adjustable levelers. Between the legs of the frame (overall width less 3") is open space for either mobile or suspended cabinets.

ENVISION DOUBLE WORK BENCH

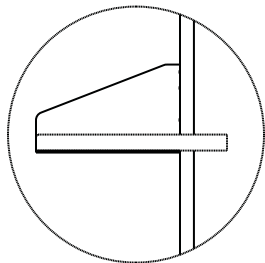
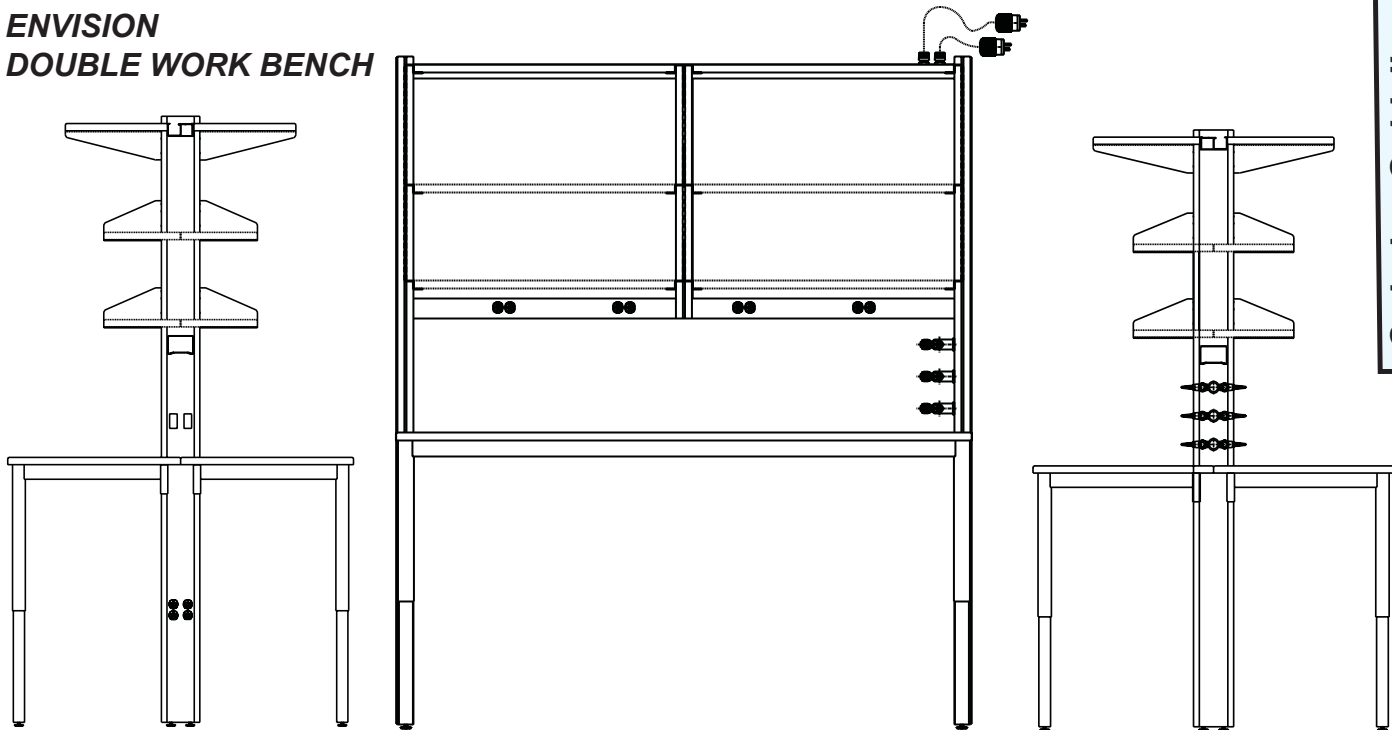

BOOK-END SHELVING WITH BRACKETS

Book-end shelves for ENVISION are available in depths of 12", 15" or 18"; with bracket sizes available in 9", 12" or 15" depths. Shelves are 1" thick, and set in 3" into the space between uprights.

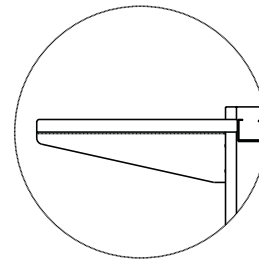

INVERTED SHELVING

Inverted shelving for ENVISION is available in depths of 10", 13" or 16"; and brackets are 9", 12" or 15" in depth. The brackets anchor in the uprights, adding stability to the shelf at the top of the unit.

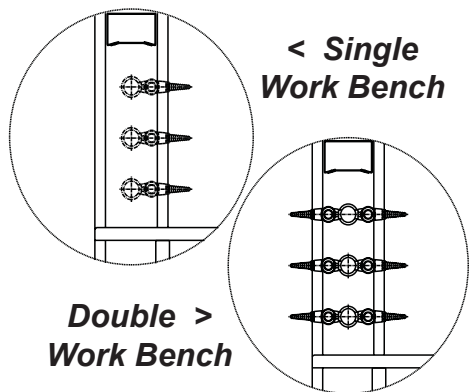

PLUMBING, ELECTRICAL, DATA OPTIONS

Plumbing, data and electrical options are varied for the ENVISION work bench.

All plumbing, electrical, data/phone positions are pre-drilled and plugged until you list your options for the bench. Each of these options must be ordered separately.

Two, pre-wired duplex outlets, inside lower, left upright are standard.

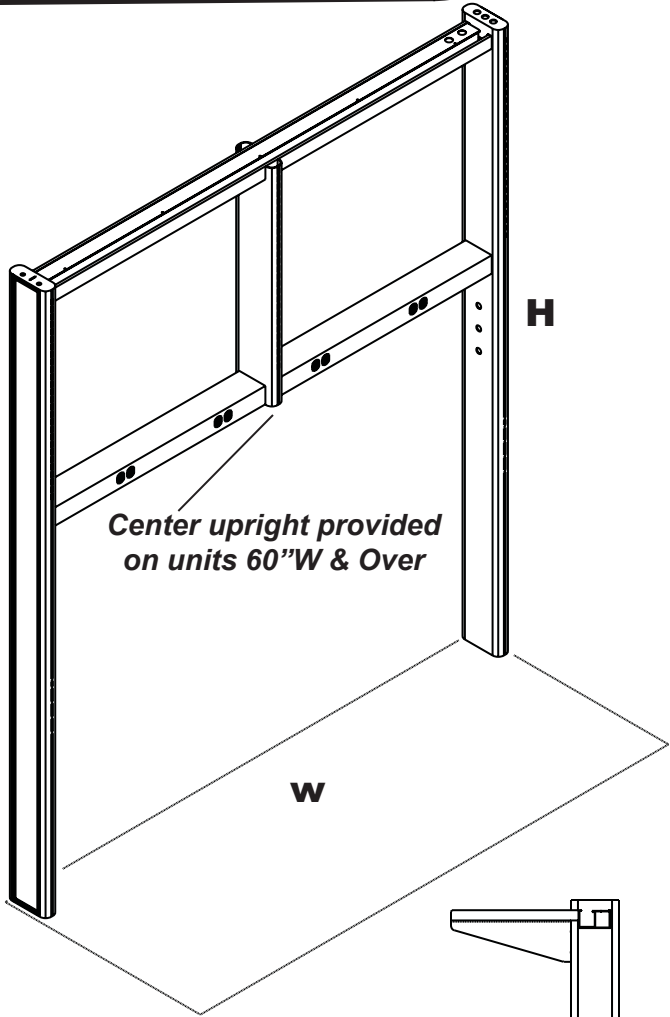

Note: Uprights measure 2" x 6"

CATALOG #	DESCRIPTION
ED2IPU-42	42" W 84" H
ED2IPU-48	48" W 84" H
ED2IPU-60	60" W 84" H
ED2IPU-72	72" W 84" H
ED2IPU-84	84" W 84" H
ED2IPU-96	96" W 84" H

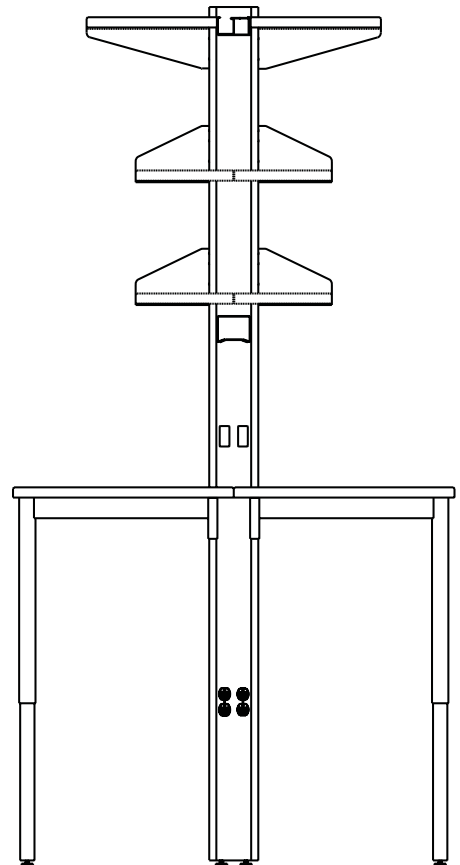
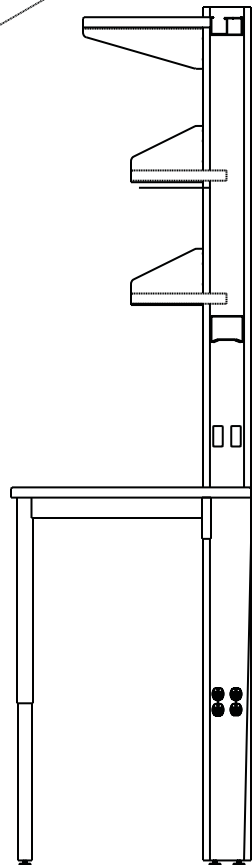

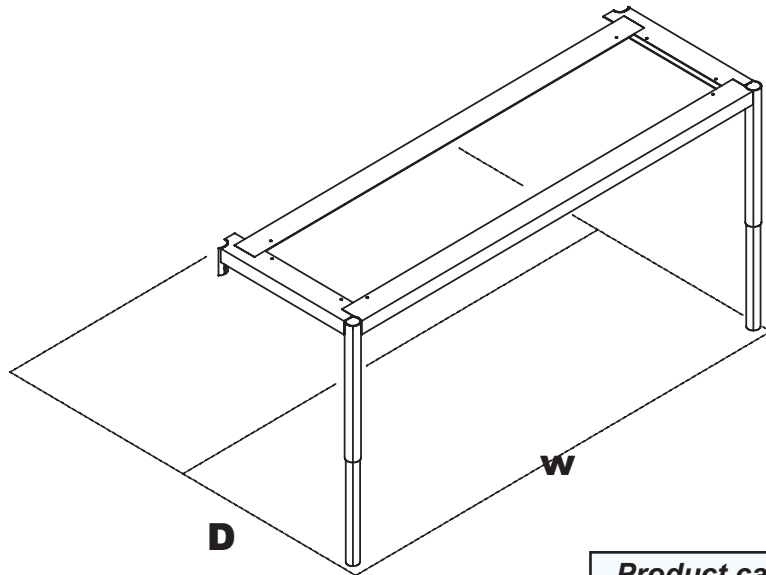

Product catalog numbers represent one (1) SINGLE, painted, frame/counter top support. For DOUBLE frames, order two (2).

ENVISION Work Bench

Single Frame - Counter Top Support

SINGLE
Frame
Depth

	42" W	48"W	60"W	72"W	84"W	96"W
24" D	ED2IPF-1842	ED2IPF-1848	ED2IPF-1860	ED2IPF-1872	ED2IPF-1884	ED2IPF-1896
30" D	ED2IPF-2442	ED2IPF-2448	ED2IPF-2460	ED2IPF-2472	ED2IPF-2484	ED2IPF-2496
33" D	ED2IPF-2742	ED2IPF-2748	ED2IPF-2760	ED2IPF-2772	ED2IPF-2784	ED2IPF-2796
36" D	ED2IPF-3042	ED2IPF-3048	ED2IPF-3060	ED2IPF-3072	ED2IPF-3084	ED2IPF-3096

Single counter tops (ED1) are available in black phenolic or black epoxy resin.
 Counter tops are one (1") thick work surfaces for the single painted frame.
 Each is designed with a 6" x 2-1/4" insets at the back allowing for uprights.
 Single counter tops are available in six width and four depth combinations.
 The insets reduce the back edge width by 5-1/2".

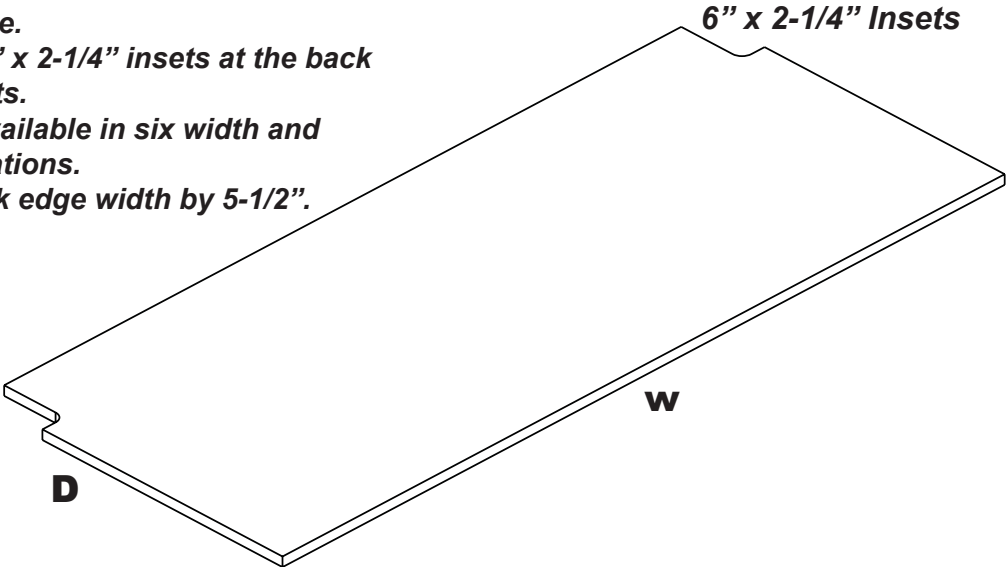

Overall Dimension*
 (*ALL 1" thick)

Black Phenolic
 Catalog #

Black Epoxy Resin
 Catalog #

42" W x 30" D
 48" W x 30" D
 60" W x 30" D
 72" W x 30" D
 84" W x 30" D
 96" W x 30" D

ED1-601
 ED1-602
 ED1-603
 ED1-604
 ED1-605
 ED1-606

ED1-801
 ED1-802
 ED1-803
 ED1-804
 ED1-805
 ED1-806

42" W x 24" D
 48" W x 24" D
 60" W x 24" D
 72" W x 24" D
 84" W x 24" D
 96" W x 24" D

ED1-621
 ED1-622
 ED1-623
 ED1-624
 ED1-625
 ED1-626

ED1-821
 ED1-822
 ED1-823
 ED1-824
 ED1-825
 ED1-826

42" W x 33" D
 48" W x 33" D
 60" W x 33" D
 72" W x 33" D
 84" W x 33" D
 96" W x 33" D

ED1-641
 ED1-642
 ED1-643
 ED1-644
 ED1-645
 ED1-646

ED1-841
 ED1-842
 ED1-843
 ED1-844
 ED1-845
 ED1-846

42" W x 36" D
 48" W x 36" D
 60" W x 36" D
 72" W x 36" D
 84" W x 36" D
 96" W x 36" D

ED1-661
 ED1-662
 ED1-663
 ED1-664
 ED1-665
 ED1-666

ED1-861
 ED1-862
 ED1-863
 ED1-864
 ED1-865
 ED1-866

Double counter tops (ED2) are available in black phenolic or black epoxy resin.

Counter tops are one (1") thick work surfaces for the double painted frame. Order two per table.

Each is designed with a 3" x 2-1/4" inset at the back allowing for uprights.

Double counter tops are available in six width and four depth combinations.

The insets reduce the back edge width by 5-1/2".

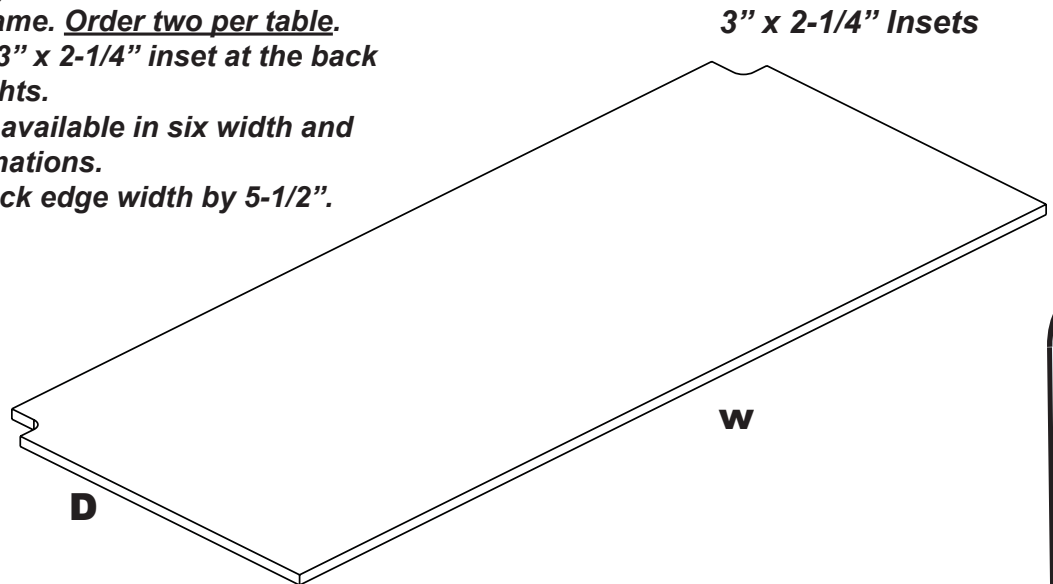

Counter Top

Overall Dimension*
(*ALL 1" thick)

Black Phenolic
Catalog #

Black Epoxy Resin
Catalog #

42" W x 30" D
48" W x 30" D
60" W x 30" D
72" W x 30" D
84" W x 30" D
96" W x 30" D

ED2-611
ED2-612
ED2-613
ED2-614
ED2-615
ED2-616

ED2-811
ED2-812
ED2-813
ED2-814
ED2-815
ED2-816

42" W x 24" D
48" W x 24" D
60" W x 24" D
72" W x 24" D
84" W x 24" D
96" W x 24" D

ED2-631
ED2-632
ED2-633
ED2-634
ED2-635
ED2-636

ED2-831
ED2-832
ED2-833
ED2-834
ED2-835
ED2-836

42" W x 33" D
48" W x 33" D
60" W x 33" D
72" W x 33" D
84" W x 33" D
96" W x 33" D

ED2-651
ED2-652
ED2-653
ED2-654
ED2-655
ED2-656

ED2-851
ED2-852
ED2-853
ED2-854
ED2-855
ED2-856

42" W x 36" D
48" W x 36" D
60" W x 36" D
72" W x 36" D
84" W x 36" D
96" W x 36" D

ED2-671
ED2-672
ED2-673
ED2-674
ED2-675
ED2-676

ED2-871
ED2-872
ED2-873
ED2-874
ED2-875
ED2-876

**SINGLE Bench Plumbing Fixtures
EP2SBV**

*Single, WaterSaver Instrument Valve,
Chrome-Plated, Brass Fixture*

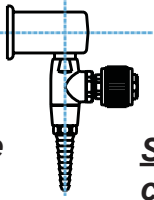

First, designate position of valve being ordered:

- Lower position
- Middle position
- Upper position

Second, begin with EP2SBV, then designate connection from options listed.

Third, designate service function for the fixture by selecting the index color button.



Plain Pipe

- C = Copper Pipe
- S = Stainless Steel Pipe
- P = PFA Plastic Tube

P = Simple Tube End

Examples:
EP2SBVCP,
EP2SBVSP, or
EP2SBVPP

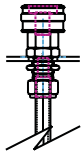

**Swagelock
Quick Disconnect
(Bulkhead)**

- C = Copper Pipe
- S = Stainless Steel Pipe
- P = PFA Plastic Tube

Q = Swagelock Quick Disconnect (Bulkhead)

Examples:
EP2SBVCQ,
EP2SBVSQ, or
EP2SBVPQ

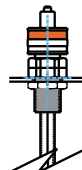

**WaterSaver
Quick Disconnect
(Stem)**

- C = Copper Pipe
- S = Stainless Steel Pipe
- P = PFA Plastic Tube

W = WaterSaver Quick Disconnect (Stem)

Examples:
EP2SBVCW,
EP2SBVSW, or
EP2SBVPW

**SERVICE FUNCTION &
INDEX COLORS**

- K1 = Helium/Black
- K2 = Air/Orange
- K3 = Cold Water/Orange
- K4 = Vacuum/Yellow
- K5 = Gas/Blue
- K6 = Natural Gas/White
- K7 = Argon/Purple
- K8 = Nitrogen/Brown

**EXAMPLES OF SINGLE BENCH PLUMBING FIXTURE ORDER,
FINAL INFORMATION:**

- Lower position, EP2SBVSW-K3
- Middle position, EP2SBVSW-K4
- Upper position, EP2SBVSW-K5
- or
- Lower position, EP2SBVCQ-K1
- Middle position, EP2SBVCQ-K6
- Upper position, EP2SBVCQ-K7
- or
- Lower position, EP2SBVPP-K2
- Middle position, EP2SBVPP-K3
- Upper position, EP2SBVPP-K4

**DOUBLE Bench Plumbing Fixtures
EP2DBV**

*Double, WaterSaver Instrument Valve,
Chrome-Plated, Brass Fixture*

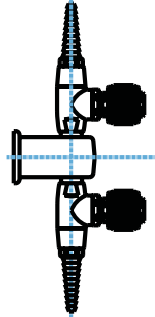

First, designate position of valve being ordered:

- Lower position
- Middle position
- Upper position

Second, begin with EP2DBV, then designate connection from options listed.

Third, designate service function for the fixture by selecting the index color button.



Plain Pipe

- C = Copper Pipe
- S = Stainless Steel Pipe
- P = PFA Plastic Tube

P = Simple Tube End

Examples:

- EP2DBVCP,
- EP2DBVSP, or
- EP2DBVPP

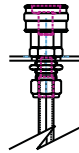

**Swagelock
Quick Disconnect
(Bulkhead)**

- C = Copper Pipe
- S = Stainless Steel Pipe
- P = PFA Plastic Tube

Q = Swagelock Quick Disconnect (Bulkhead)

Examples:

- EP2SBVCQ,
- EP2SBVSQ, or
- EP2SBVPQ

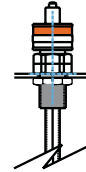

**WaterSaver
Quick Disconnect
(Stem)**

- C = Copper Pipe
- S = Stainless Steel Pipe
- P = PFA Plastic Tube

W = WaterSaver Quick Disconnect (Stem)

Examples:

- EP2SBVCW,
- EP2SBVSW, or
- EP2SBVPW

Plumbing

**SERVICE FUNCTION &
INDEX COLORS**

- K1 = Helium/Black
- K2 = Air/Orange
- K3 = Cold Water/Orange
- K4 = Vacuum/Yellow
- K5 = Gas/Blue
- K6 = Natural Gas/White
- K7 = Argon/Purple
- K8 = Nitrogen/Brown

**EXAMPLES OF DOUBLE BENCH PLUMBING FIXTURE ORDER,
FINAL INFORMATION:**

- Lower position, EP2DBVSW-K3
- Middle position, EP2DBVSW-K4
- Upper position, EP2DBVSW-K5
- or
- Lower position, EP2DBVCQ-K1
- Middle position, EP2DBVCQ-K6
- Upper position, EP2DBVCQ-K7
- or
- Lower position, EP2DBVPP-K2
- Middle position, EP2DBVPP-K3
- Upper position, EP2DBVPP-K4

Used with 240v outlets or 2, 120v circuits with shared neutral & ground

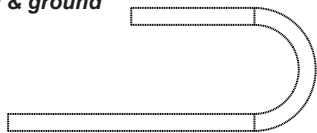
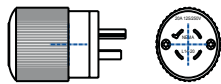

Plug
125V & 250V/20A
TWISTLOK,
NEMA L14-20

Cord
125V & 250V/20A
Cord, 12AWG/ 4 Wire,
Black, 4 ft. long

Used with single circuit.

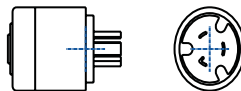

Plug
125V/20A
TWISTLOK,
NEMA L15-20

Cord
125V/20A
Cord, 12AWG/ 3 Wire,
Black, 4 ft. long.

TYPICAL ELECTRICAL WIRING OPTIONS

42" W & 48" W Benches

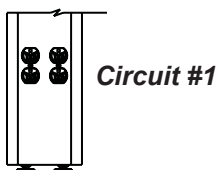
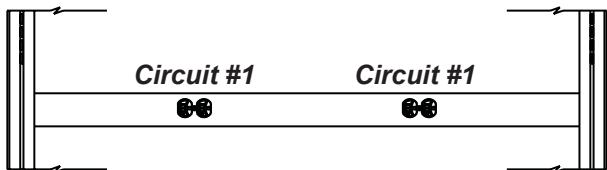
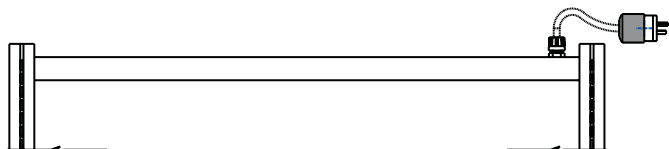

NOTE:

EW1 = Outlets, one side
EW2 = Outlets, both sides

2 outlets, lower left, inside up-right post, are standard with any electrical package

Single Circuit, Single Plug

All on single circuit.

Equipped with:

125V/20A plug & 3-wire cord
125V/20A duplex outlets

EW142A 42" W bench
EW148A 48" W bench

EW242A 42" W bench,
outlets both sides

EW248A 48" W bench,
outlets both sides

Double Circuit, Single Plug

Equipped with:

125V & 250 V/20A plug & 4-wire cord
125V/20A duplex outlets

EW142B 42" W bench
EW148B 48" W bench

EW242B 42" W bench,
outlets both sides

EW248B 48" W bench,
outlets both sides

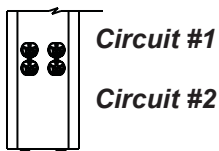
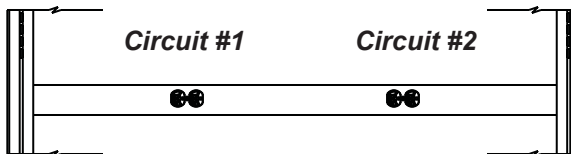
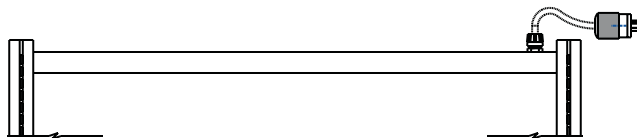

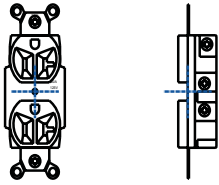

Duplex Outlet
20A, 125V
Specification Grade
Grey

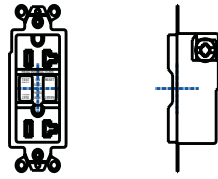

Duplex Outlet, G.F.I.
20A, 125V
Commercial Grade
Grey



Cord Connector
1/2", Liquid Tight,
Grey
(Also requires conduit nut.)

TYPICAL ELECTRICAL WIRING OPTIONS

42" W & 48" W Benches

NOTE:

EW1 = Outlets, one side
EW2 = Outlets, both sides

2 outlets, lower left, inside upright post, are standard with any electrical package

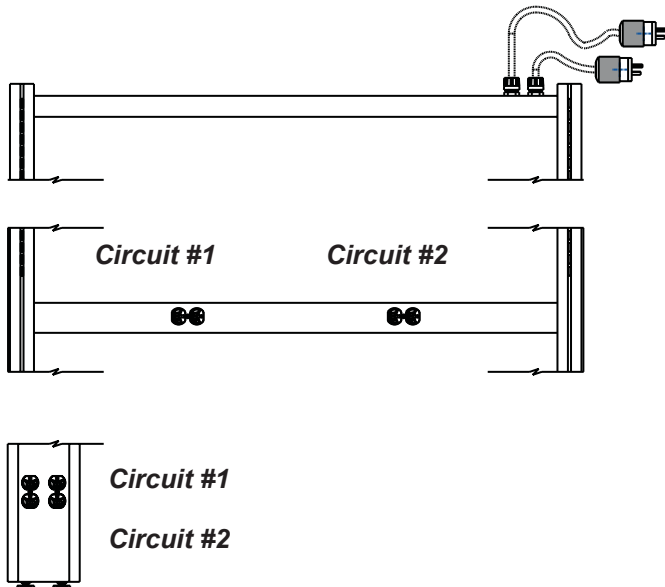

Double Circuit, Double Plugs

Equipped with:

2, 125V/20A plug & 3-wire cord
125V/20A duplex outlets

EW142A 42" W bench
EW148A 48" W bench

EW242A 42" W bench,
outlets both sides

EW248A 48" W bench,
outlets both sides

Electrical

Used with 240v outlets or 2, 120v circuits with shared neutral & ground

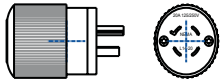

Plug
125V & 250V/20A
TWISTLOK,
NEMA L14-20

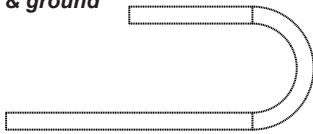

Cord
125V & 250V/20A
Cord, 12AWG/ 4 Wire,
Black, 4 ft. long

Used with single circuit.

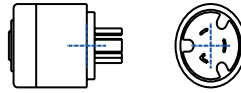

Plug
125V/20A
TWISTLOK,
NEMA L15-20



Cord
125V/20A
Cord, 12AWG/ 3 Wire,
Black, 4 ft. long.

TYPICAL ELECTRICAL WIRING OPTIONS

60" W, 72" W, 84" W & 96" W Benches

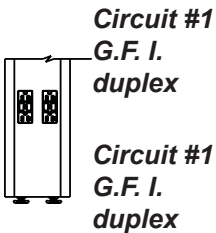
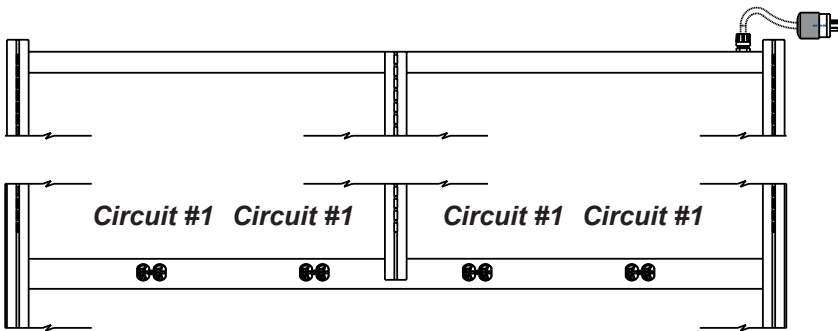

NOTE:

EW1 = Outlets, one side
EW2 = Outlets, both sides

2 outlets, inside lower left, upright post, are standard with any electrical package.

Single Circuit, Single Plug

All on single circuit.

NOTE: Six (6) or more outlets on a single circuit require G.F.I. circuit protection.

Equipped with:

125V/20A plug & 3-wire cord
125V/20A duplex outlets

EW160A 60" W bench
EW172A 72" W bench
EW184A 84" W bench
EW196A 96" W bench

EW260A 60" W bench,
outlets both sides
EW272A 72" W bench,
outlets both sides
EW284A 84" W bench,
outlets both sides
EW296A 96" W bench,
outlets both sides

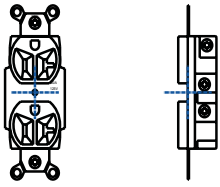

Duplex Outlet
20A, 125V
Specification Grade
Grey

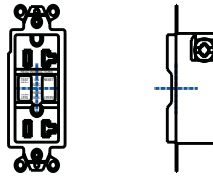

Duplex Outlet, G.F.I.
20A, 125V
Commercial Grade
Grey



Cord Connector
1/2", Liquid Tight,
Grey
(Also requires conduit nut.)

TYPICAL ELECTRICAL WIRING OPTIONS

60" W, 72" W, 84" W & 96" W Benches

NOTE:

EW1 = Outlets, one side
EW2 = Outlets, both sides

2 outlets, inside lower left, upright post, are standard with any electrical package.

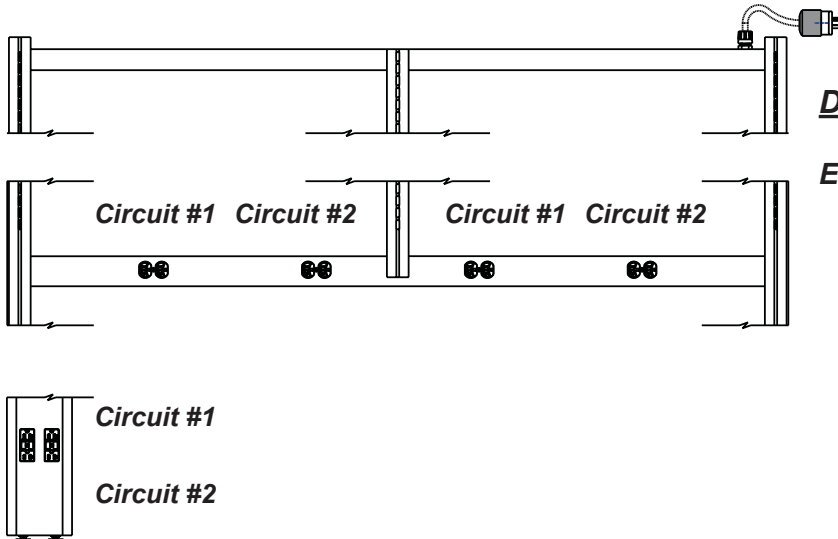

Double Circuit, Single Plug

Equipped with:

125V & 250V/20A plug & 4-wire cord
125V/20A duplex outlets

- EW160B 60" W bench
- EW172B 72" W bench
- EW184B 84" W bench
- EW196B 96" W bench

- EW260B 60" W bench, outlets both sides
- EW272B 72" W bench, outlets both sides
- EW284B 84" W bench, outlets both sides
- EW296B 96" W bench, outlets both sides

Electrical

Used with 240v outlets or 2, 120v circuits with shared neutral & ground

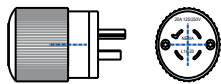

Plug
125V & 250V/20A
TWISTLOK,
NEMA L14-20

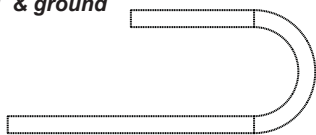

Cord
125V & 250V/20A
Cord, 12AWG/ 4 Wire,
Black, 4 ft. long

Used with single circuit.

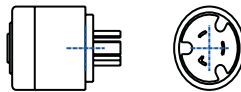

Plug
125V/20A
TWISTLOK,
NEMA L15-20



Cord
125V/20A
Cord, 12AWG/ 3 Wire,
Black, 4 ft. long.

TYPICAL ELECTRICAL WIRING OPTIONS

60" W, 72" W, 84" W & 96" W Benches

NOTE:

EW1 = Outlets, one side

EW2 = Outlets, both sides

2 outlets, inside lower left, upright post, are standard with any electrical package.

Double Circuit, Double Plug

Equipped with:

2, 125V/20A plugs & 3-wire cords

125V/20A duplex outlets

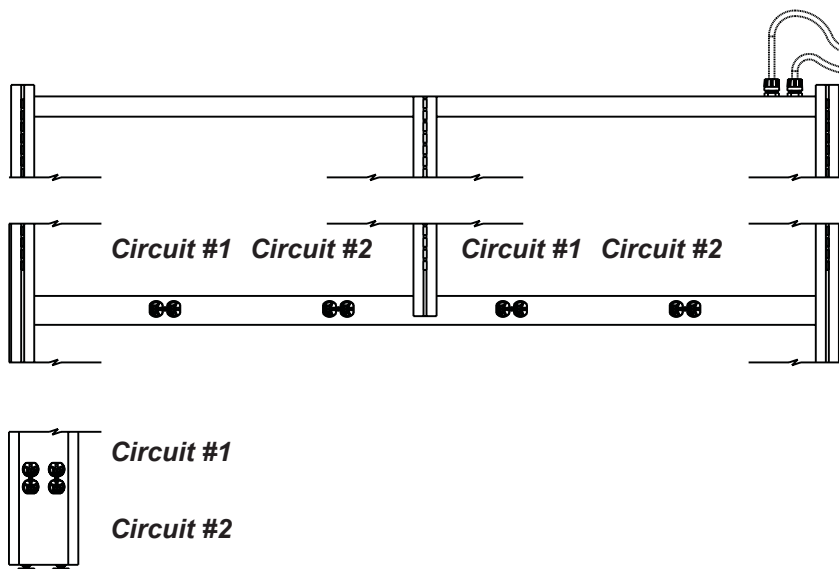

EW160C 60" W bench
EW172C 72" W bench
EW184C 84" W bench
EW196C 96" W bench

EW260C 60" W bench,
outlets both sides
EW272C 72" W bench,
outlets both sides
EW284C 84" W bench,
outlets both sides
EW296C 96" W bench,
outlets both sides

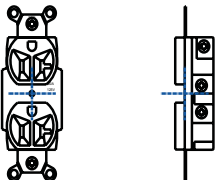

Duplex Outlet
20A, 125V
Specification Grade
Grey

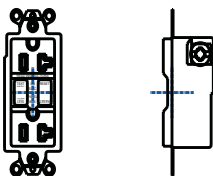

Duplex Outlet, G.F.I.
20A, 125V
Commercial Grade
Grey



Cord Connector
1/2", Liquid Tight,
Grey
(Also requires conduit nut.)

TYPICAL ELECTRICAL WIRING OPTIONS

60" W & 72" W Benches

NOTE:

EW1 = Outlets, one side
EW2 = Outlets, both sides

2 outlets, inside lower left, upright post, are standard with any electrical package.

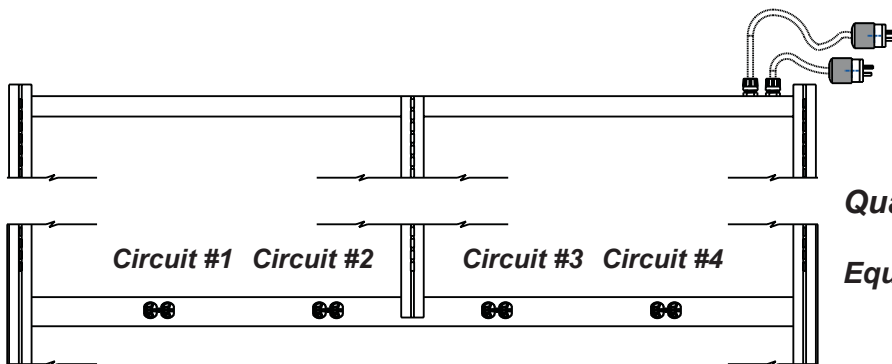

Quad/Circuit, Double Plugs

Equipped with:

- 2, 125V & 250V/20A plugs & 4-wire cords
- 125V/20A duplex outlets

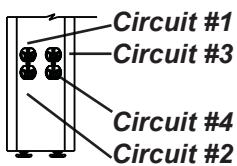

- EW160D 60" W bench
- EW172D 72" W bench
- EW184D 84" W bench
- EW196D 96" W bench

- EW260D 60" W bench, outlets both sides
- EW272D 72" W bench, outlets both sides
- EW284D 84" W bench, outlets both sides
- EW296D 96" W bench, outlets both sides

Electrical

Used with 240v outlets or 2, 120v circuits with shared neutral & ground

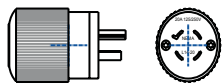

Plug
125V & 250V/20A
TWISTLOK,
NEMA L14-20

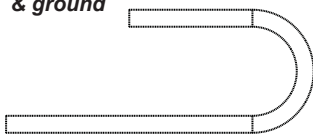

Cord
125V & 250V/20A
Cord, 12AWG/ 4 Wire,
Black, 4 ft. long

Used with single circuit.

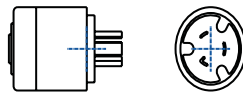

Plug
125V/20A
TWISTLOK,
NEMA L15-20

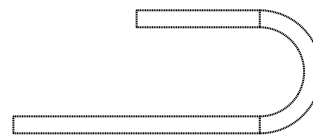

Cord
125V/20A
Cord, 12AWG/ 3 Wire,
Black, 4 ft. long.

TYPICAL ELECTRICAL WIRING OPTIONS

60" W & 72" W Benches

NOTE:

EW1 = Outlets, one side
EW2 = Outlets, both sides

2 outlets, inside lower left, upright post, are standard with any electrical package.

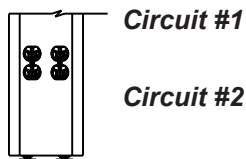
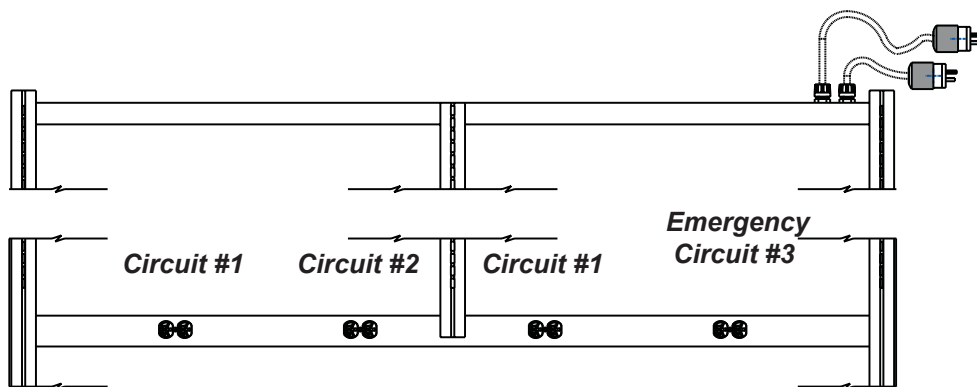

Double Circuit,
with One Emergency Circuit,
Double Plugs

Equipped with:

- 1, 125V & 250V/20A plug & 4-wire cord, and
- 1, 125V/20A plug & 3-wire cord as Emergency Circuit.
- 125V/20A duplex outlets

- | | |
|--------|------------------------------------|
| EW160E | 60" W bench |
| EW172E | 72" W bench |
| EW260D | 60" W bench,
outlets both sides |
| EW272D | 72" W bench,
outlets both sides |

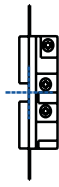

Duplex Outlet
20A, 125V
Specification Grade
Grey



Duplex Outlet, G.F.I.
20A, 125V
Commercial Grade
Grey

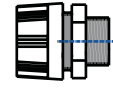

Cord Connector
1/2", Liquid Tight,
Grey
(Also requires conduit nut.)

TYPICAL ELECTRICAL WIRING OPTIONS

60" W & 72" W Benches

NOTE:

EW1 = Outlets, one side
EW2 = Outlets, both sides

2 outlets, inside lower left, upright post, are standard with any electrical package.

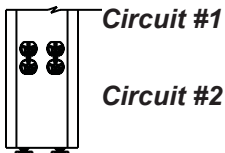
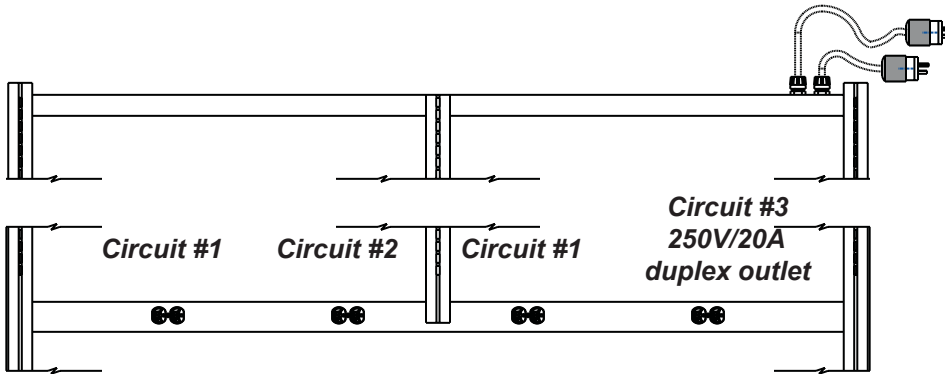

Double Circuit,
with One (1), 250V Outlet
Double Plugs

Equipped with:

- 2, 125V & 250 V/20A plugs & 4-wire cords
- 1, 250 V duplex outlet, and 125V/20A duplex outlets

EW160V 60" W bench
EW172V 72" W bench

EW260V 60" W bench,
 outlets both sides
EW272V 72" W bench,
 outlets both sides

Electrical

ENVISION

Shelving Assembly

Phenolic Shelves

Painted

Book End With Accessories

12" Deep Shelves

42" W & 48" W are full width

Shelves for 60" W, 72" W, 84" W & 96" W Units are Half (H*) Width. Order TWO.

PLAIN

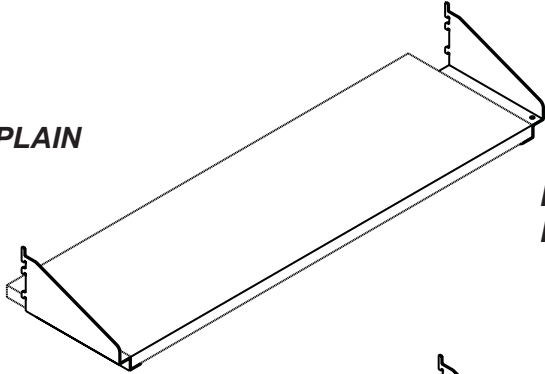

PLAIN:
Painted

ESP	Unit #	Overall Width
ESP	BPA-1242	42" W
ESP	BPA-1248	48" W
ESP	BPA-1260H* (order 2)	60" W
ESP	BPA-1272H* (order 2)	72" W
ESP	BPA-1284H* (order 2)	84" W
ESP	BPA-1296H* (order 2)	96" W

w/Aluminum Rod, Front

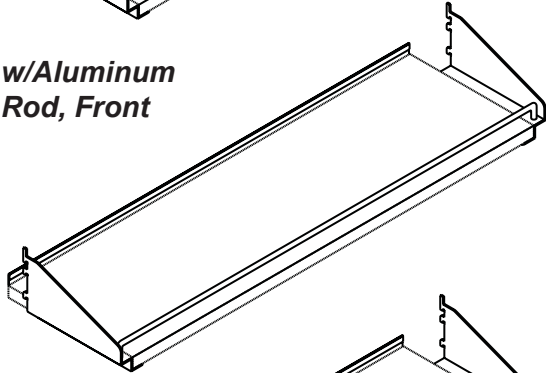

W/ALUMINUM ROD, FRONT:
Painted

ESP	Unit #	Overall Width
ESP	BPR-1242	42" W
ESP	BPR-1248	48" W
ESP	BPR-1260H* (order 2)	60" W
ESP	BPR-1272H* (order 2)	72" W
ESP	BPR-1284H* (order 2)	84" W
ESP	BPR-1296H* (order 2)	96" W

w/Shelf Lip Rear

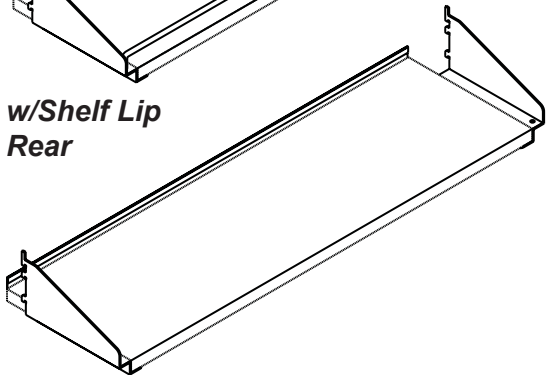

W/SHELF LIP, REAR:
Painted

ESP	Unit #	Overall Width
ESP	BPL-1242	42" W
ESP	BPL-1248	48" W
ESP	BPL-1260H* (order 2)	60" W
ESP	BPL-1272H* (order 2)	72" W
ESP	BPL-1284H* (order 2)	84" W
ESP	BPL-1296H* (order 2)	96" W

w/Aluminum Rod, Front & Shelf Lip, Rear

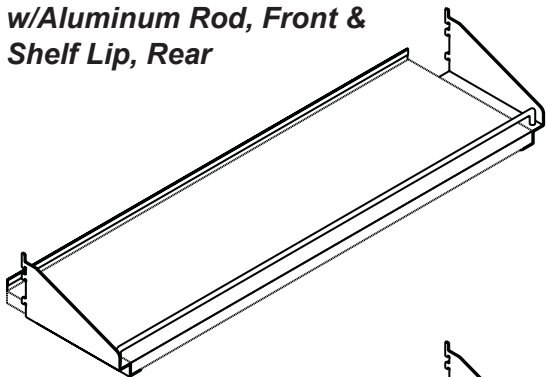

W/ALUMINUM ROD, FRONT & SHELF LIP, REAR:

ESP	Unit #	Overall Width
ESP	BPB-1242	42" W
ESP	BPB-1248	48" W
ESP	BPB-1260H* (order 2)	60" W
ESP	BPB-1272H* (order 2)	72" W
ESP	BPB-1284H* (order 2)	84" W
ESP	BPB-1296H* (order 2)	96" W

w/Shelf Lips, Front & Rear

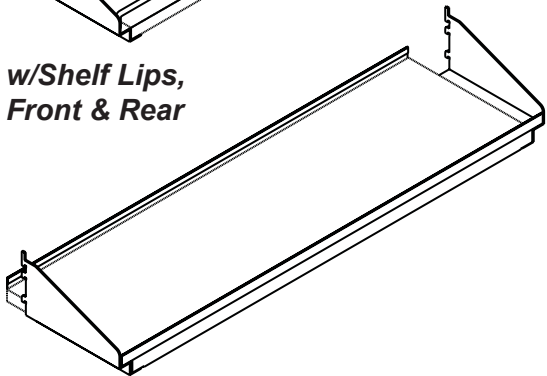

W/SHELF LIPS, FRONT & REAR:

ESP	Unit #	Overall Width
ESP	BPX-1242	42" W
ESP	BPX-1248	48" W
ESP	BPX-1260H* (order 2)	60" W
ESP	BPX-1272H* (order 2)	72" W
ESP	BPX-1284H* (order 2)	84" W
ESP	BPX-1296H* (order 2)	96" W

Shelving Assembly

Phenolic Shelves

Painted

Inverted Bracket With Accessories

10" Deep Shelves

42" W & 48" W are full width

Shelves for 60" W, 72" W, 84" W & 96" W Units are Half (H*) Width. Order TWO.

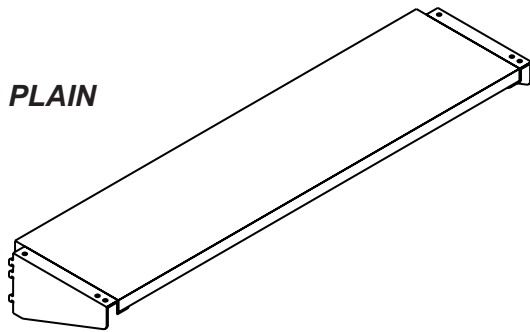

PLAIN

PLAIN:

Painted

	Unit #	Overall Width
ESP	IPA-1042	42" W
ESP	IPA-1048	48" W
ESP	IPA-1060H* (order 2)	60" W
ESP	IPA-1072H* (order 2)	72" W
ESP	IPA-1084H* (order 2)	84" W
ESP	IPA-1096H* (order 2)	96" W

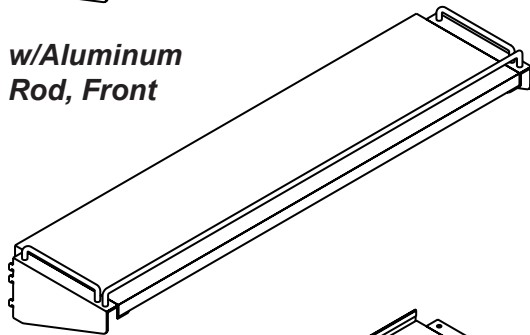

w/Aluminum Rod, Front

W/ALUMINUM ROD, FRONT:

Painted

	Unit #	Overall Width
ESP	IPR-1042	42" W
ESP	IPR-1048	48" W
ESP	IPR-1060H* (order 2)	60" W
ESP	IPR-1072H* (order 2)	72" W
ESP	IPR-1084H* (order 2)	84" W
ESP	IPR-1096H* (order 2)	96" W

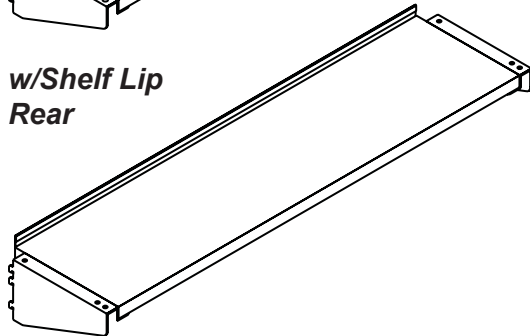

w/Shelf Lip Rear

W/SHELF LIP, REAR:

Painted

	Unit #	Overall Width
ESP	IPL-1042	42" W
ESP	IPL-1048	48" W
ESP	IPL-1060H* (order 2)	60" W
ESP	IPL-1072H* (order 2)	72" W
ESP	IPL-1084H* (order 2)	84" W
ESP	IPL-1096H* (order 2)	96" W

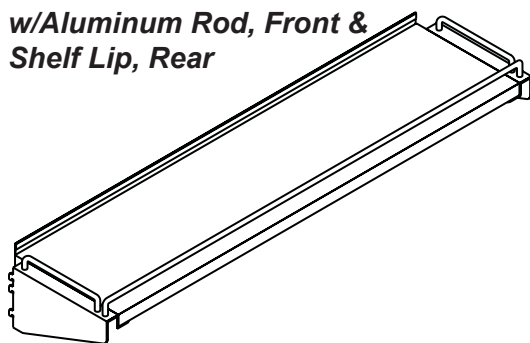

w/Aluminum Rod, Front & Shelf Lip, Rear

W/ALUMINUM ROD, FRONT & SHELF LIP, REAR:

Painted

	Unit #	Overall Width
ESP	IPB-1042	42" W
ESP	IPB-1048	48" W
ESP	IPB-1060H* (order 2)	60" W
ESP	IPB-1072H* (order 2)	72" W
ESP	IPB-1084H* (order 2)	84" W
ESP	IPB-1096H* (order 2)	96" W

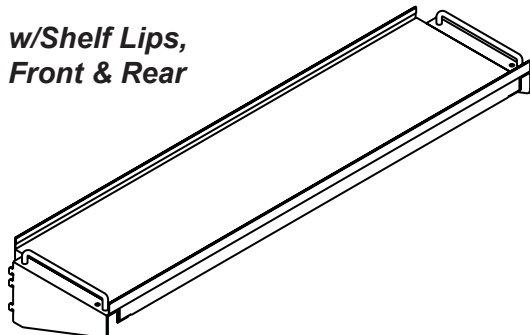

w/Shelf Lips, Front & Rear

W/SHELF LIPS, FRONT & REAR:

Painted

	Unit #	Overall Width
ESP	IPX-1042	42" W
ESP	IPX-1048	48" W
ESP	IPX-1060H* (order 2)	60" W
ESP	IPX-1072H* (order 2)	72" W
ESP	IPX-1084H* (order 2)	84" W
ESP	IPX-1096H* (order 2)	96" W

Shelves - Phenolic

ENVISION

Shelving Assembly

Phenolic Shelves

Painted

Book End With Accessories

15" Deep Shelves

42" W & 48" W are full width

Shelves for 60" W, 72" W, 84" W & 96" W Units are Half (H*) Width. Order TWO.

PLAIN

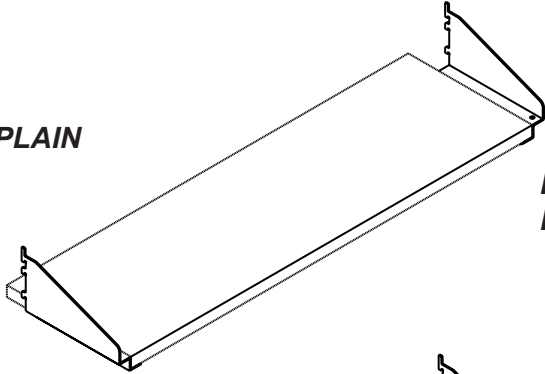

PLAIN:

Painted

Unit #	Overall Width
ESP BPA-1542	42" W
ESP BPA-1548	48" W
ESP BPA-1560H* (order 2)	60" W
ESP BPA-1572H* (order 2)	72" W
ESP BPA-1584H* (order 2)	84" W
ESP BPA-1596H* (order 2)	96" W

w/Aluminum Rod, Front

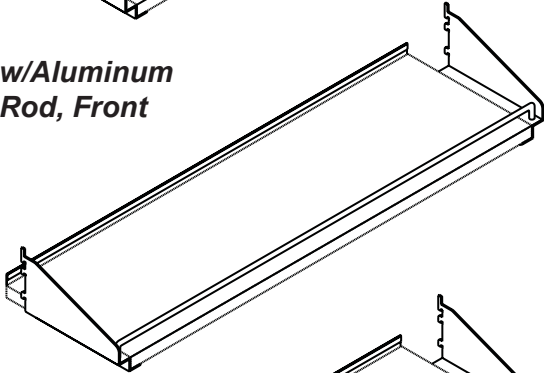

W/ALUMINUM ROD, FRONT:

Painted

Unit #	Overall Width
ESP BPR-1542	42" W
ESP BPR-1548	48" W
ESP BPR-1560H* (order 2)	60" W
ESP BPR-1572H* (order 2)	72" W
ESP BPR-1584H* (order 2)	84" W
ESP BPR-1596H* (order 2)	96" W

w/Shelf Lip Rear

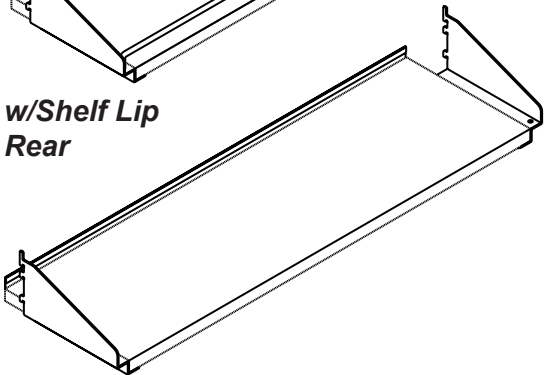

W/SHELF LIP, REAR:

Painted

Unit #	Overall Width
ESP BPL-1542	42" W
ESP BPL-1548	48" W
ESP BPL-1560H* (order 2)	60" W
ESP BPL-1572H* (order 2)	72" W
ESP BPL-1584H* (order 2)	84" W
ESP BPL-1596H* (order 2)	96" W

w/Aluminum Rod, Front & Shelf Lip, Rear

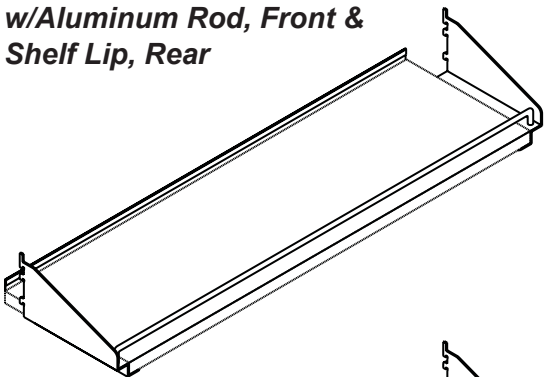

W/ALUMINUM ROD, FRONT & SHELF LIP, REAR:

Painted

Unit #	Overall Width
ESP BPB-1542	42" W
ESP BPB-1548	48" W
ESP BPB-1560H* (order 2)	60" W
ESP BPB-1572H* (order 2)	72" W
ESP BPB-1584H* (order 2)	84" W
ESP BPB-1596H* (order 2)	96" W

w/Shelf Lips, Front & Rear

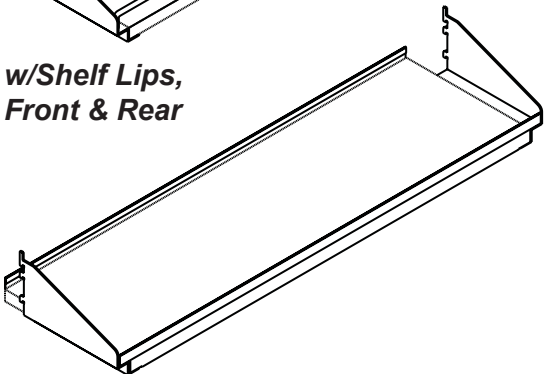

W/SHELF LIPS, FRONT & REAR:

Painted

Unit #	Overall Width
ESP BPX-1542	42" W
ESP BPX-1548	48" W
ESP BPX-1560H* (order 2)	60" W
ESP BPX-1572H* (order 2)	72" W
ESP BPX-1584H* (order 2)	84" W
ESP BPX-1596H* (order 2)	96" W

Phenolic Shelves

Painted

Inverted Bracket With Accessories

13" Deep Shelves

42" W & 48" W are full width

Shelves for 60" W, 72" W, 84" W & 96" W Units are Half (H*) Width. Order TWO.

PLAIN

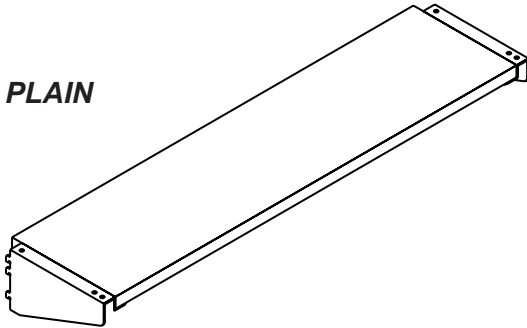

PLAIN:

Painted

	Unit #	Overall Width
ESP	IPA-1342	42" W
ESP	IPA-1348	48" W
ESP	IPA-1360H* (order 2)	60" W
ESP	IPA-1372H* (order 2)	72" W
ESP	IPA-1384H* (order 2)	84" W
ESP	IPA-1396H* (order 2)	96" W

w/Aluminum Rod, Front

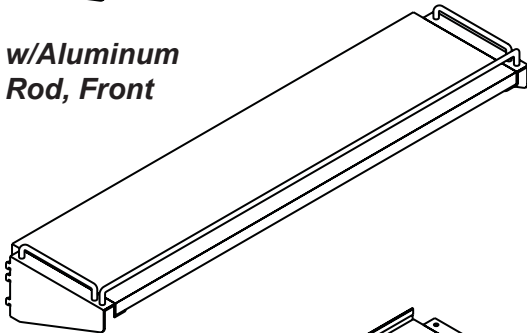

W/ALUMINUM ROD, FRONT:

Painted

	Unit #	Overall Width
ESP	IPR-1342	42" W
ESP	IPR-1348	48" W
ESP	IPR-1360H* (order 2)	60" W
ESP	IPR-1372H* (order 2)	72" W
ESP	IPR-1384H* (order 2)	84" W
ESP	IPR-1396H* (order 2)	96" W

w/Shelf Lip Rear

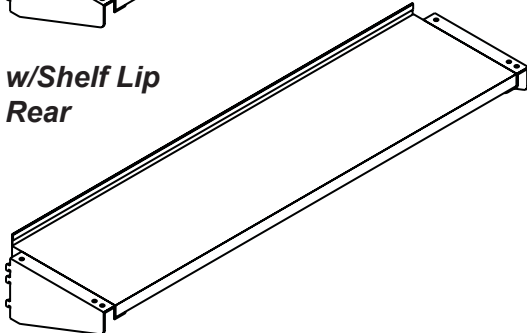

W/SHELF LIP, REAR:

Painted

	Unit #	Overall Width
ESP	IPL-1342	42" W
ESP	IPL-1348	48" W
ESP	IPL-1360H* (order 2)	60" W
ESP	IPL-1372H* (order 2)	72" W
ESP	IPL-1384H* (order 2)	84" W
ESP	IPL-1396H* (order 2)	96" W

w/Aluminum Rod, Front & Shelf Lip, Rear

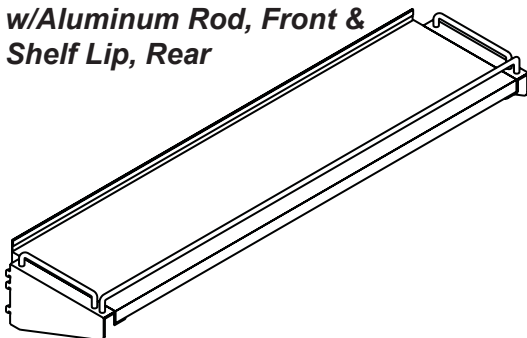

W/ALUMINUM ROD, FRONT & SHELF LIP, REAR:

Painted

	Unit #	Overall Width
ESP	IPB-1342	42" W
ESP	IPB-1348	48" W
ESP	IPB-1360H* (order 2)	60" W
ESP	IPB-1372H* (order 2)	72" W
ESP	IPB-1384H* (order 2)	84" W
ESP	IPB-1396H* (order 2)	96" W

w/Shelf Lips, Front & Rear

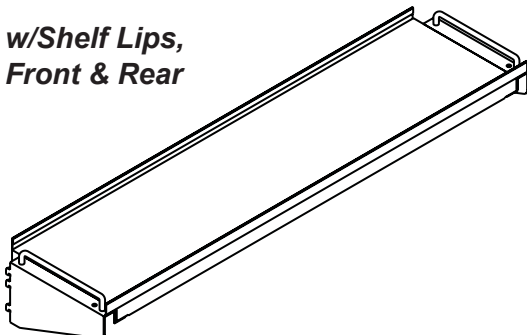

W/SHELF LIPS, FRONT & REAR:

Painted

	Unit #	Overall Width
ESP	IPX-1342	42" W
ESP	IPX-1348	48" W
ESP	IPX-1360H* (order 2)	60" W
ESP	IPX-1372H* (order 2)	72" W
ESP	IPX-1384H* (order 2)	84" W
ESP	IPX-1396H* (order 2)	96" W

Shelves - Phenolic

Shelving Assembly

Phenolic Shelves

Painted

Book End With Accessories

18" Deep Shelves

42" W & 48" W are full width

Shelves for 60" W, 72" W, 84" W & 96" W Units are Half (H*) Width. Order TWO.

PLAIN

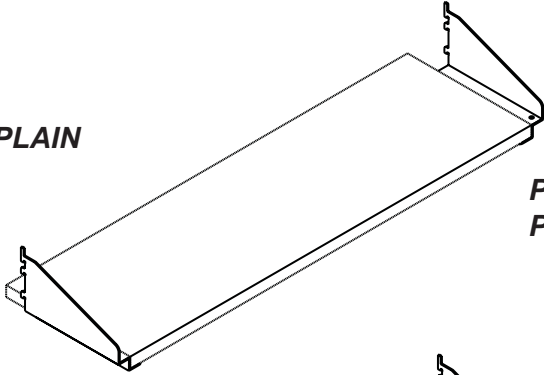

PLAIN:
Painted

ESP	Unit #	Overall Width
ESP	BPA-1842	42" W
ESP	BPA-1848	48" W
ESP	BPA-1860H* (order 2)	60" W
ESP	BPA-1872H* (order 2)	72" W
ESP	BPA-1884H* (order 2)	84" W
ESP	BPA-1896H* (order 2)	96" W

w/Aluminum Rod, Front

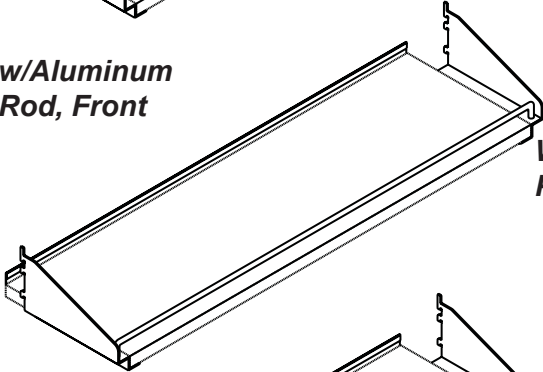

W/ALUMINUM ROD, FRONT:
Painted

ESP	Unit #	Overall Width
ESP	BPR-1842	42" W
ESP	BPR-1848	48" W
ESP	BPR-1860H* (order 2)	60" W
ESP	BPR-1872H* (order 2)	72" W
ESP	BPR-1884H* (order 2)	84" W
ESP	BPR-1896H* (order 2)	96" W

w/Shelf Lip Rear

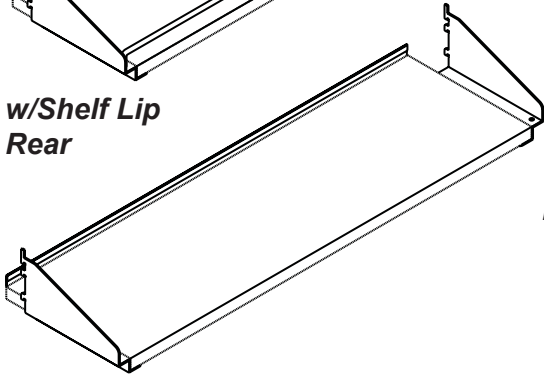

W/SHELF LIP, REAR:
Painted

ESP	Unit #	Overall Width
ESP	BPL-1842	42" W
ESP	BPL-1848	48" W
ESP	BPL-1860H* (order 2)	60" W
ESP	BPL-1872H* (order 2)	72" W
ESP	BPL-1884H* (order 2)	84" W
ESP	BPL-1896H* (order 2)	96" W

w/Aluminum Rod, Front & Shelf Lip, Rear

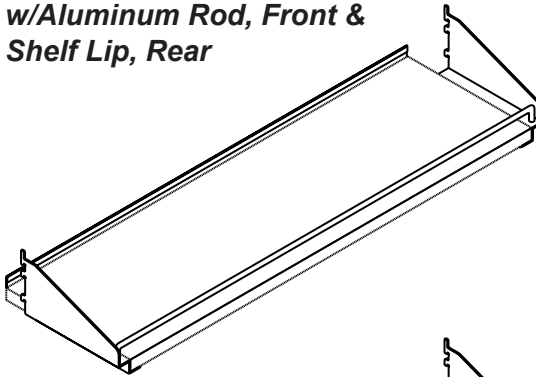

W/ALUMINUM ROD, FRONT & SHELF LIP, REAR:

ESP	Unit #	Overall Width
ESP	BPB-1842	42" W
ESP	BPB-1848	48" W
ESP	BPB-1860H* (order 2)	60" W
ESP	BPB-1872H* (order 2)	72" W
ESP	BPB-1884H* (order 2)	84" W
ESP	BPB-1896H* (order 2)	96" W

w/Shelf Lips, Front & Rear

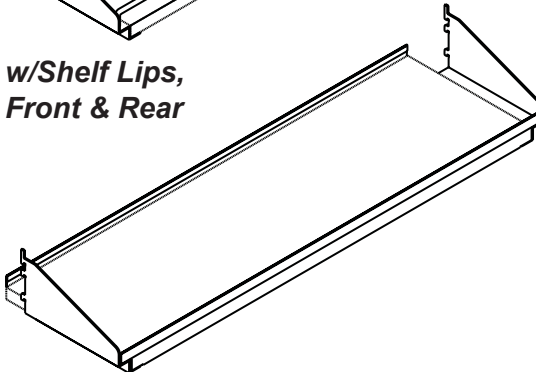

W/SHELF LIPS, FRONT & REAR:

ESP	Unit #	Overall Width
ESP	BPX-1842	42" W
ESP	BPX-1848	48" W
ESP	BPX-1860H* (order 2)	60" W
ESP	BPX-1872H* (order 2)	72" W
ESP	BPX-1884H* (order 2)	84" W
ESP	BPX-1896H* (order 2)	96" W

Phenolic Shelves

Painted

Inverted Bracket With Accessories

16" Deep Shelves

42" W & 48" W are full width

Shelves for 60" W, 72" W, 84" W & 96" W Units are Half (H*) Width. Order TWO.

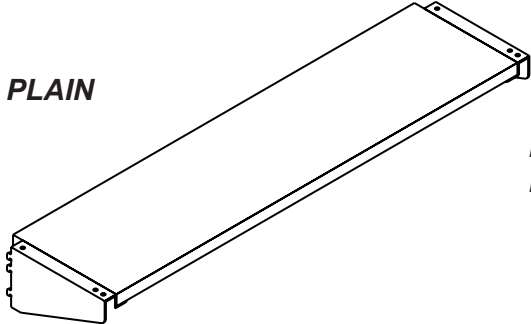

PLAIN

PLAIN:

Painted

Unit #	Overall Width
ESP IPA-1642	42" W
ESP IPA-1648	48" W
ESP IPA-1660H* (order 2)	60" W
ESP IPA-1672H* (order 2)	72" W
ESP IPA-1684H* (order 2)	84" W
ESP IPA-1696H* (order 2)	96" W

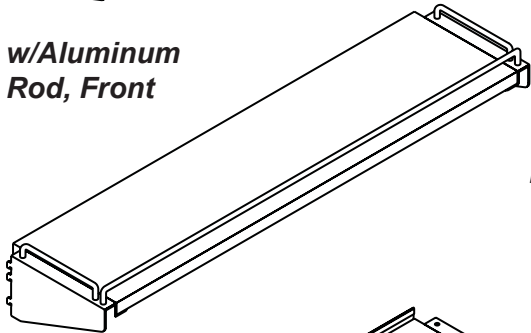

w/Aluminum Rod, Front

W/ALUMINUM ROD, FRONT:

Painted

Unit #	Overall Width
ESP IPR-1642	42" W
ESP IPR-1648	48" W
ESP IPR-1660H* (order 2)	60" W
ESP IPR-1672H* (order 2)	72" W
ESP IPR-1684H* (order 2)	84" W
ESP IPR-1696H* (order 2)	96" W

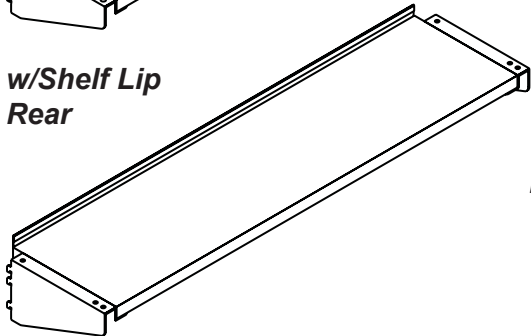

w/Shelf Lip Rear

W/SHELF LIP, REAR:

Painted

Unit #	Overall Width
ESP IPL-1642	42" W
ESP IPL-1648	48" W
ESP IPL-1660H* (order 2)	60" W
ESP IPL-1672H* (order 2)	72" W
ESP IPL-1684H* (order 2)	84" W
ESP IPL-1696H* (order 2)	96" W

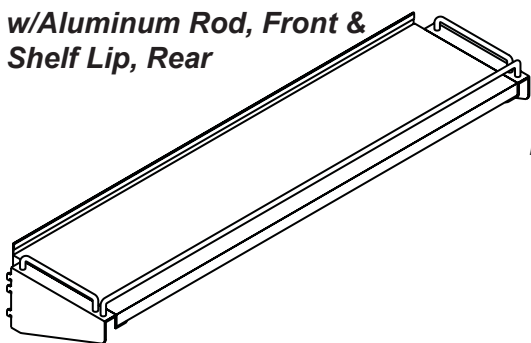

w/Aluminum Rod, Front & Shelf Lip, Rear

W/ALUMINUM ROD, FRONT & SHELF LIP, REAR:

Painted

Unit #	Overall Width
ESP IPB-1642	42" W
ESP IPB-1648	48" W
ESP IPB-1660H* (order 2)	60" W
ESP IPB-1672H* (order 2)	72" W
ESP IPB-1684H* (order 2)	84" W
ESP IPB-1696H* (order 2)	96" W

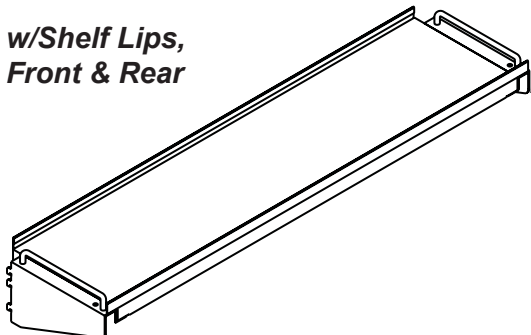

w/Shelf Lips, Front & Rear

W/SHELF LIPS, FRONT & REAR:

Painted

Unit #	Overall Width
ESP IPX-1642	42" W
ESP IPX-1648	48" W
ESP IPX-1660H* (order 2)	60" W
ESP IPX-1672H* (order 2)	72" W
ESP IPX-1684H* (order 2)	84" W
ESP IPX-1696H* (order 2)	96" W

Shelves - Phenolic

ENVISION

Shelving Assembly

Painted Steel Shelves

Book End With Accessories

12" Deep Shelves

42" W & 48" W are full width

Shelves for 60" W, 72" W, 84" W & 96" W Units are Half (H*) Width. Order TWO.

PLAIN

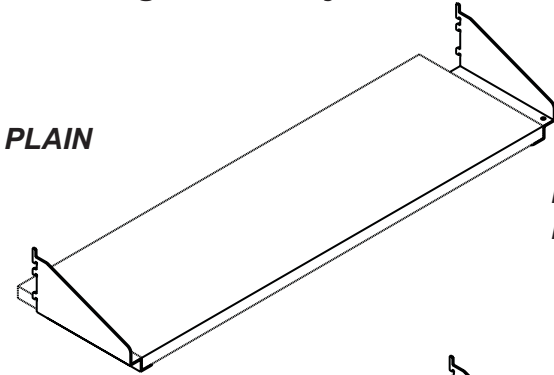

PLAIN:

Painted

	Unit #	Overall Width
ESP	BSA-1242	42" W
ESP	BSA-1248	48" W
ESP	BSA-1260H* (order 2)	60" W
ESP	BSA-1272H* (order 2)	72" W
ESP	BSA-1284H* (order 2)	84" W
ESP	BSA-1296H* (order 2)	96" W

w/Aluminum Rod, Front

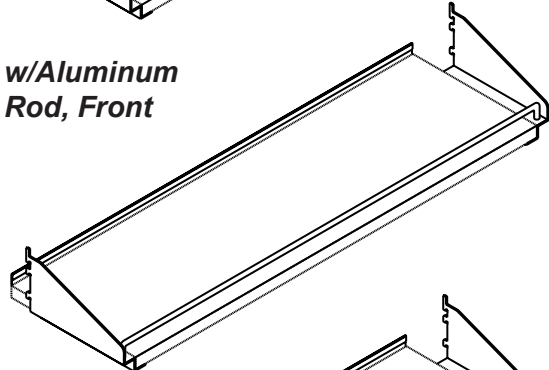

W/ALUMINUM ROD, FRONT:

Painted

	Unit #	Overall Width
ESP	BSR-1242	42" W
ESP	BSR-1248	48" W
ESP	BSR-1260H* (order 2)	60" W
ESP	BSR-1272H* (order 2)	72" W
ESP	BSR-1284H* (order 2)	84" W
ESP	BSR-1296H* (order 2)	96" W

w/Shelf Lip Rear

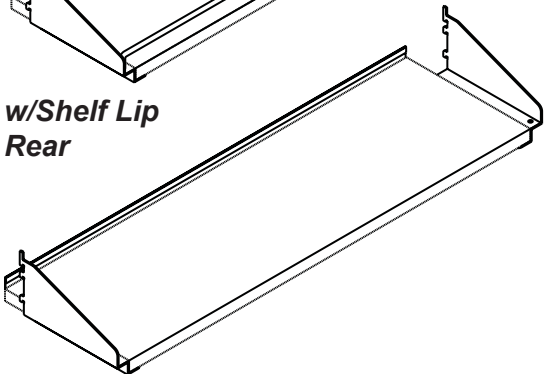

W/SHELF LIP, REAR:

Painted

	Unit #	Overall Width
ESP	BSL-1242	42" W
ESP	BSL-1248	48" W
ESP	BSL-1260H* (order 2)	60" W
ESP	BSL-1272H* (order 2)	72" W
ESP	BSL-1284H* (order 2)	84" W
ESP	BSL-1296H* (order 2)	96" W

w/Aluminum Rod, Front & Shelf Lip, Rear

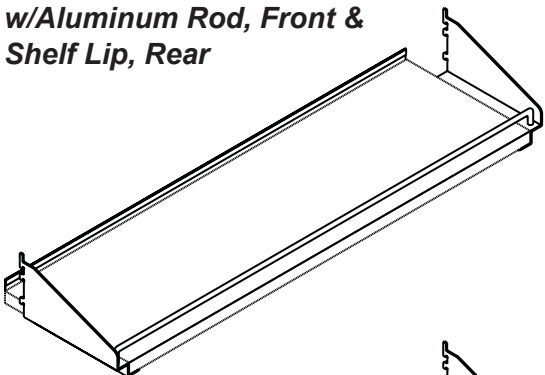

W/ALUMINUM ROD, FRONT & SHELF LIP, REAR:

Painted

	Unit #	Overall Width
ESP	BSB-1242	42" W
ESP	BSB-1248	48" W
ESP	BSB-1260H* (order 2)	60" W
ESP	BSB-1272H* (order 2)	72" W
ESP	BSB-1284H* (order 2)	84" W
ESP	BSB-1296H* (order 2)	96" W

w/Shelf Lips, Front & Rear

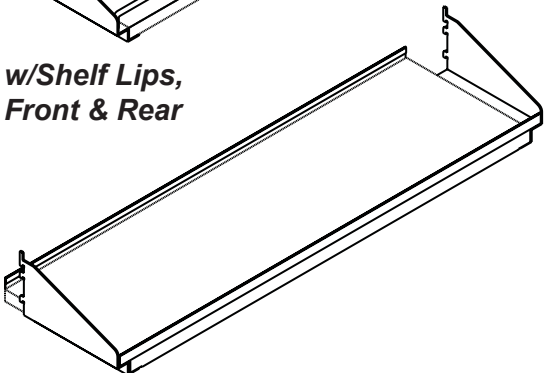

W/SHELF LIPS, FRONT & REAR:

Painted

	Unit #	Overall Width
ESP	BSX-1242	42" W
ESP	BSX-1248	48" W
ESP	BSX-1260H* (order 2)	60" W
ESP	BSX-1272H* (order 2)	72" W
ESP	BSX-1284H* (order 2)	84" W
ESP	BSX-1296H* (order 2)	96" W

Shelving Assembly

Painted Steel Shelves

Inverted Bracket With Accessories

10" Deep Shelves

42" W & 48" W are full width

Shelves for 60" W, 72" W, 84" W & 96" W Units are Half (H*) Width. Order TWO.

PLAIN

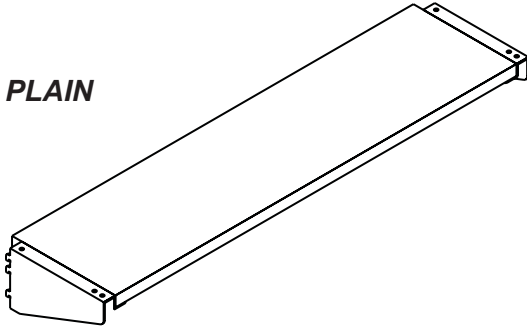

PLAIN:

Painted

	Unit #	Overall Width
ESP	ISA-1042	42" W
ESP	ISA-1048	48" W
ESP	ISA-1060H* (order 2)	60" W
ESP	ISA-1072H* (order 2)	72" W
ESP	ISA-1084H* (order 2)	84" W
ESP	ISA-1096H* (order 2)	96" W

w/Aluminum Rod, Front

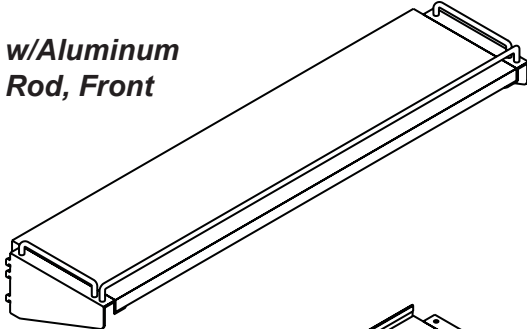

W/ALUMINUM ROD, FRONT:

Painted

	Unit #	Overall Width
ESP	ISR-1042	42" W
ESP	ISR-1048	48" W
ESP	ISR-1060H* (order 2)	60" W
ESP	ISR-1072H* (order 2)	72" W
ESP	ISR-1084H* (order 2)	84" W
ESP	ISR-1096H* (order 2)	96" W

w/Shelf Lip Rear

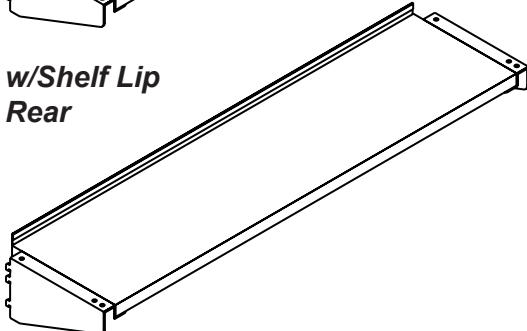

W/SHELF LIP, REAR:

Painted

	Unit #	Overall Width
ESP	ISL-1042	42" W
ESP	ISL-1048	48" W
ESP	ISL-1060H* (order 2)	60" W
ESP	ISL-1072H* (order 2)	72" W
ESP	ISL-1084H* (order 2)	84" W
ESP	ISL-1096H* (order 2)	96" W

w/Aluminum Rod, Front & Shelf Lip, Rear

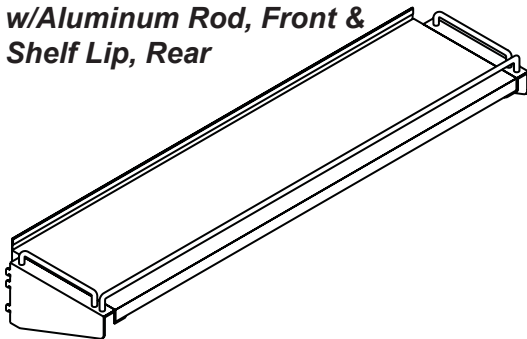

W/ALUMINUM ROD, FRONT & SHELF LIP, REAR:

Painted

	Unit #	Overall Width
ESP	ISB-1042	42" W
ESP	ISB-1048	48" W
ESP	ISB-1060H* (order 2)	60" W
ESP	ISB-1072H* (order 2)	72" W
ESP	ISB-1084H* (order 2)	84" W
ESP	ISB-1096H* (order 2)	96" W

w/Shelf Lips, Front & Rear

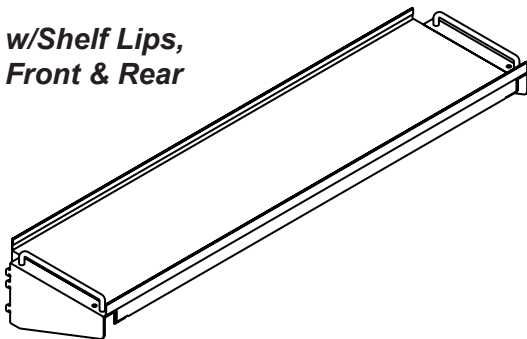

W/SHELF LIPS, FRONT & REAR:

Painted

	Unit #	Overall Width
ESP	ISX-1042	42" W
ESP	ISX-1048	48" W
ESP	ISX-1060H* (order 2)	60" W
ESP	ISX-1072H* (order 2)	72" W
ESP	ISX-1084H* (order 2)	84" W
ESP	ISX-1096H* (order 2)	96" W

Shelves Painted Steel

Painted Steel Shelves

Book End With Accessories

15" Deep Shelves

42" W & 48" W are full width

Shelves for 60" W, 72" W, 84" W & 96" W Units are Half (H*) Width. Order TWO.

PLAIN

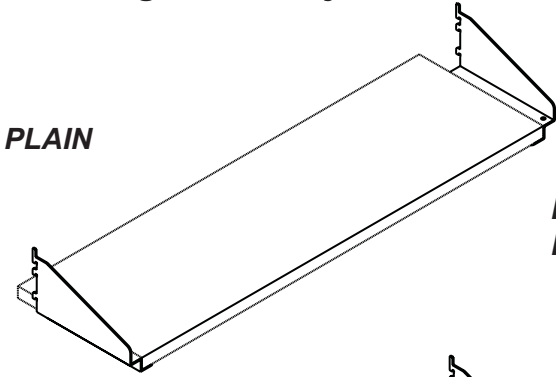

PLAIN:

Painted	Unit #	Overall Width
ESP	BSA-1542	42" W
ESP	BSA-1548	48" W
ESP	BSA-1560H* (order 2)	60" W
ESP	BSA-1572H* (order 2)	72" W
ESP	BSA-1584H* (order 2)	84" W
ESP	BSA-1596H* (order 2)	96" W

w/Aluminum Rod, Front

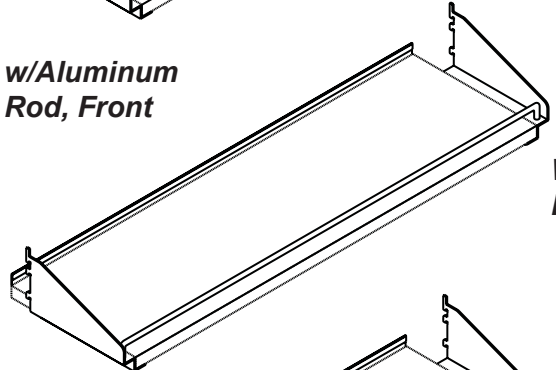

W/ALUMINUM ROD, FRONT:

Painted	Unit #	Overall Width
ESP	BSR-1542	42" W
ESP	BSR-1548	48" W
ESP	BSR-1560H* (order 2)	60" W
ESP	BSR-1572H* (order 2)	72" W
ESP	BSR-1584H* (order 2)	84" W
ESP	BSR-1596H* (order 2)	96" W

w/Shelf Lip Rear

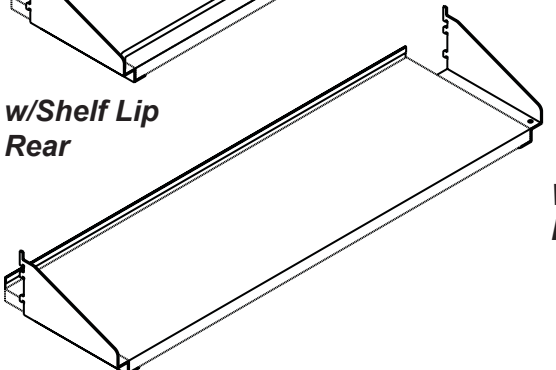

W/SHELF LIP, REAR:

Painted	Unit #	Overall Width
ESP	BSL-1542	42" W
ESP	BSL-1548	48" W
ESP	BSL-1560H* (order 2)	60" W
ESP	BSL-1572H* (order 2)	72" W
ESP	BSL-1584H* (order 2)	84" W
ESP	BSL-1596H* (order 2)	96" W

w/Aluminum Rod, Front & Shelf Lip, Rear

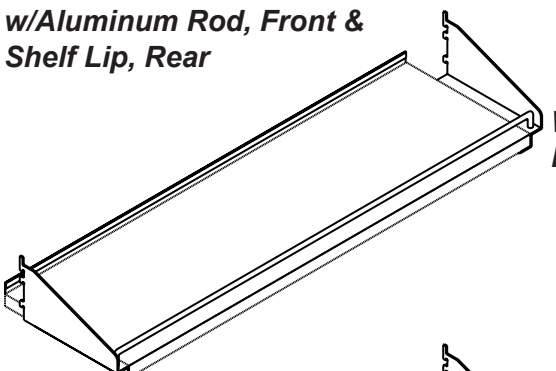

W/ALUMINUM ROD, FRONT & SHELF LIP, REAR:

Painted	Unit #	Overall Width
ESP	BSB-1542	42" W
ESP	BSB-1548	48" W
ESP	BSB-1560H* (order 2)	60" W
ESP	BSB-1572H* (order 2)	72" W
ESP	BSB-1584H* (order 2)	84" W
ESP	BSB-1596H* (order 2)	96" W

w/Shelf Lips, Front & Rear

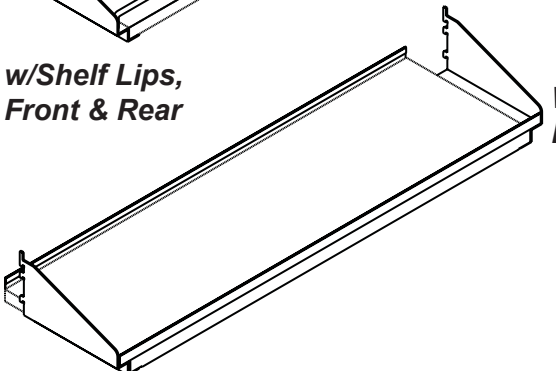

W/SHELF LIPS, FRONT & REAR:

Painted	Unit #	Overall Width
ESP	BSX-1542	42" W
ESP	BSX-1548	48" W
ESP	BSX-1560H* (order 2)	60" W
ESP	BSX-1572H* (order 2)	72" W
ESP	BSX-1584H* (order 2)	84" W
ESP	BSX-1596H* (order 2)	96" W

Shelving Assembly

Painted Steel Shelves

Inverted Bracket With Accessories

13" Deep Shelves

42" W & 48" W are full width

Shelves for 60" W, 72" W, 84" W & 96" W Units are Half (H*) Width. Order TWO.

PLAIN

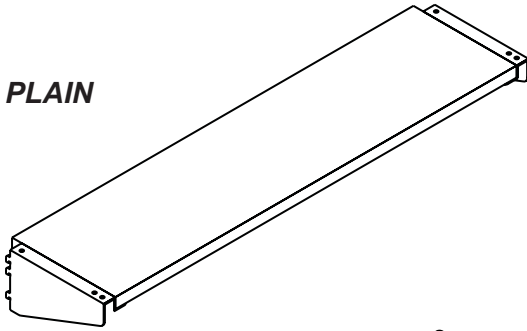

PLAIN:

Painted

ESP	Unit #	Overall Width
ESP	ISA-1342	42" W
ESP	ISA-1348	48" W
ESP	ISA-1360H* (order 2)	60" W
ESP	ISA-1372H* (order 2)	72" W
ESP	ISA-1384H* (order 2)	84" W
ESP	ISA-1396H* (order 2)	96" W

w/Aluminum Rod, Front

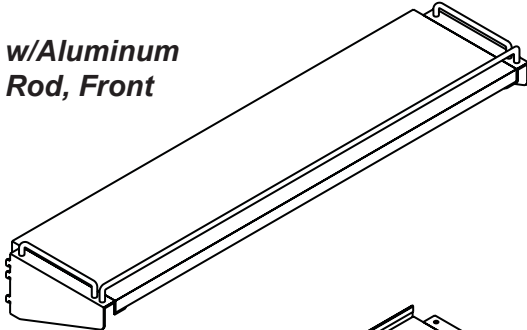

W/ALUMINUM ROD, FRONT:

Painted

ESP	Unit #	Overall Width
ESP	ISR-1342	42" W
ESP	ISR-1348	48" W
ESP	ISR-1360H* (order 2)	60" W
ESP	ISR-1372H* (order 2)	72" W
ESP	ISR-1384H* (order 2)	84" W
ESP	ISR-1396H* (order 2)	96" W

w/Shelf Lip Rear

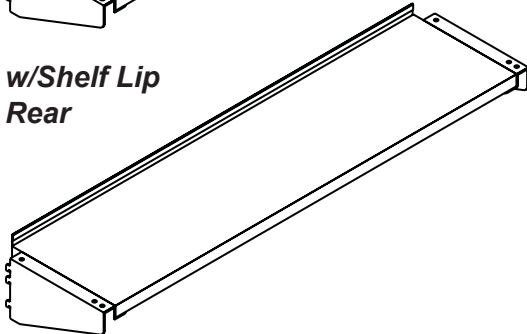

W/SHELF LIP, REAR:

Painted

ESP	Unit #	Overall Width
ESP	ISL-1342	42" W
ESP	ISL-1348	48" W
ESP	ISL-1360H* (order 2)	60" W
ESP	ISL-1372H* (order 2)	72" W
ESP	ISL-1384H* (order 2)	84" W
ESP	ISL-1396H* (order 2)	96" W

w/Aluminum Rod, Front & Shelf Lip, Rear

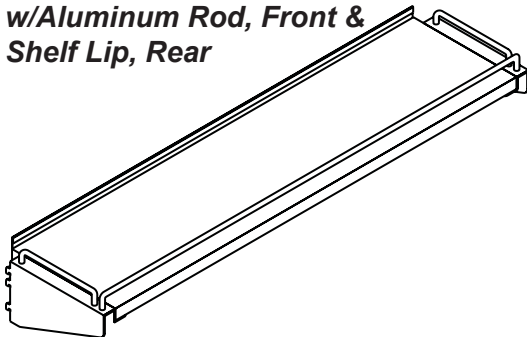

W/ALUMINUM ROD, FRONT & SHELF LIP, REAR:

Painted

ESP	Unit #	Overall Width
ESP	ISB-1342	42" W
ESP	ISB-1348	48" W
ESP	ISB-1360H* (order 2)	60" W
ESP	ISB-1372H* (order 2)	72" W
ESP	ISB-1384H* (order 2)	84" W
ESP	ISB-1396H* (order 2)	96" W

w/Shelf Lips, Front & Rear

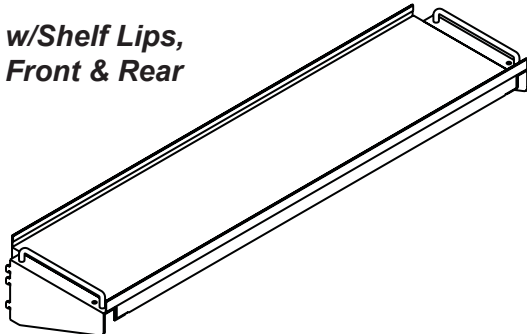

W/SHELF LIPS, FRONT & REAR:

Painted

ESP	Unit #	Overall Width
ESP	ISX-1342	42" W
ESP	ISX-1348	48" W
ESP	ISX-1360H* (order 2)	60" W
ESP	ISX-1372H* (order 2)	72" W
ESP	ISX-1384H* (order 2)	84" W
ESP	ISX-1396H* (order 2)	96" W

Shelves Painted Steel

ENVISION

Shelving Assembly

Painted Steel Shelves

Book End With Accessories

18" Deep Shelves

42" W & 48" W are full width

Shelves for 60" W, 72" W, 84" W & 96" W Units are Half (H*) Width. Order TWO.

PLAIN

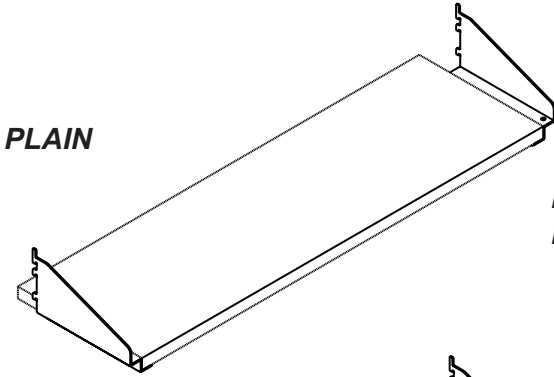

PLAIN:

Painted

	Unit #	Overall Width
ESP	BSA-1842	42" W
ESP	BSA-1848	48" W
ESP	BSA-1860H* (order 2)	60" W
ESP	BSA-1872H* (order 2)	72" W
ESP	BSA-1884H* (order 2)	84" W
ESP	BSA-1896H* (order 2)	96" W

w/Aluminum Rod, Front

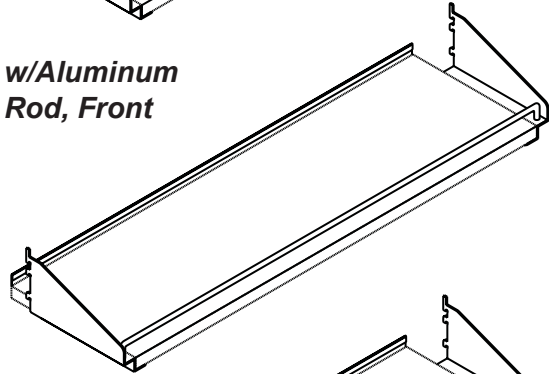

W/ALUMINUM ROD, FRONT:

Painted

	Unit #	Overall Width
ESP	BSR-1842	42" W
ESP	BPR-1848	48" W
ESP	BSR-1860H* (order 2)	60" W
ESP	BSR-1872H* (order 2)	72" W
ESP	BSR-1884H* (order 2)	84" W
ESP	BSR-1896H* (order 2)	96" W

w/Shelf Lip Rear

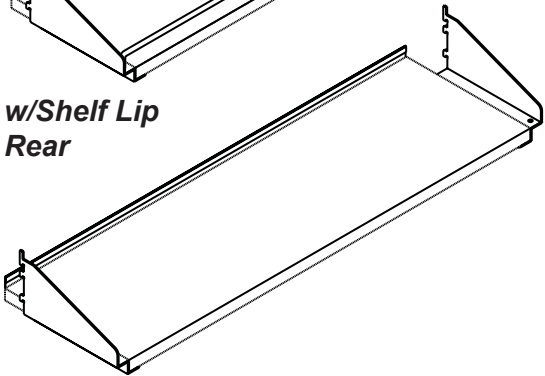

W/SHELF LIP, REAR:

Painted

	Unit #	Overall Width
ESP	BSL-1842	42" W
ESP	BSL-1848	48" W
ESP	BSL-1860H* (order 2)	60" W
ESP	BSL-1872H* (order 2)	72" W
ESP	BSL-1884H* (order 2)	84" W
ESP	BSL-1896H* (order 2)	96" W

w/Aluminum Rod, Front & Shelf Lip, Rear

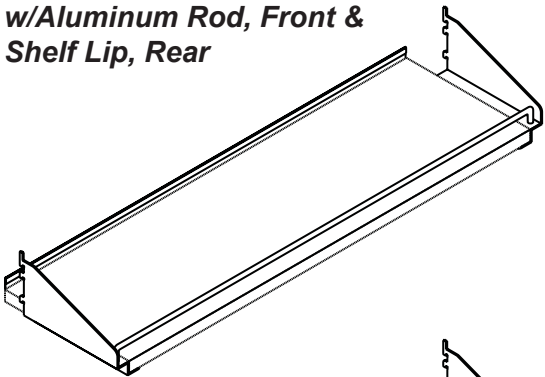

W/ALUMINUM ROD, FRONT & SHELF LIP, REAR:

Painted

	Unit #	Overall Width
ESP	BSB-1842	42" W
ESP	BSB-1848	48" W
ESP	BSB-1860H* (order 2)	60" W
ESP	BSB-1872H* (order 2)	72" W
ESP	BSB-1884H* (order 2)	84" W
ESP	BSB-1896H* (order 2)	96" W

w/Shelf Lips, Front & Rear

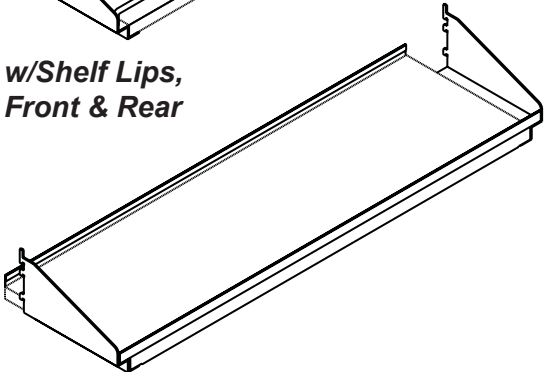

W/SHELF LIPS, FRONT & REAR:

Painted

	Unit #	Overall Width
ESP	BSX-1842	42" W
ESP	BSX-1848	48" W
ESP	BSX-1860H* (order 2)	60" W
ESP	BSX-1872H* (order 2)	72" W
ESP	BSX-1884H* (order 2)	84" W
ESP	BSX-1896H* (order 2)	96" W

ENVISION

Shelving Assembly

Painted Steel Shelves

Inverted Bracket With Accessories

16" Deep Shelves

42" W & 48" W are full width

Shelves for 60" W, 72" W, 84" W & 96" W Units are Half (H*) Width. Order TWO.

PLAIN

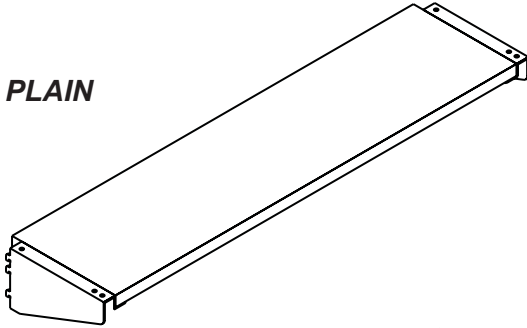

PLAIN:

Painted

	Unit #	Overall Width
ESP	ISA-1642	42" W
ESP	ISA-1648	48" W
ESP	ISA-1660H* (order 2)	60" W
ESP	ISA-1672H* (order 2)	72" W
ESP	ISA-1684H* (order 2)	84" W
ESP	ISA-1696H* (order 2)	96" W

w/Aluminum Rod, Front

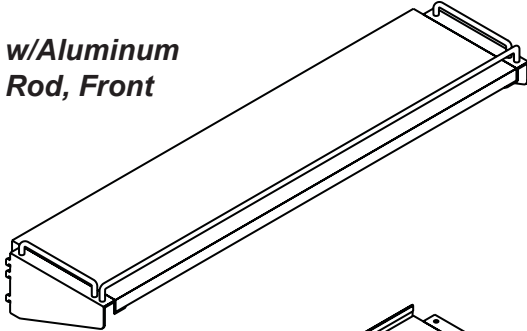

W/ALUMINUM ROD, FRONT:

Painted

	Unit #	Overall Width
ESP	ISR-1642	42" W
ESP	ISR-1648	48" W
ESP	ISR-1660H* (order 2)	60" W
ESP	ISR-1672H* (order 2)	72" W
ESP	ISR-1684H* (order 2)	84" W
ESP	ISR-1696H* (order 2)	96" W

w/Shelf Lip Rear

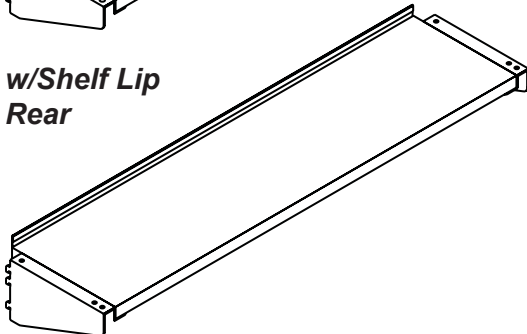

W/SHELF LIP, REAR:

Painted

	Unit #	Overall Width
ESP	ISL-1642	42" W
ESP	ISL-1648	48" W
ESP	ISL-1660H* (order 2)	60" W
ESP	ISL-1672H* (order 2)	72" W
ESP	ISL-1684H* (order 2)	84" W
ESP	ISL-1696H* (order 2)	96" W

w/Aluminum Rod, Front & Shelf Lip, Rear

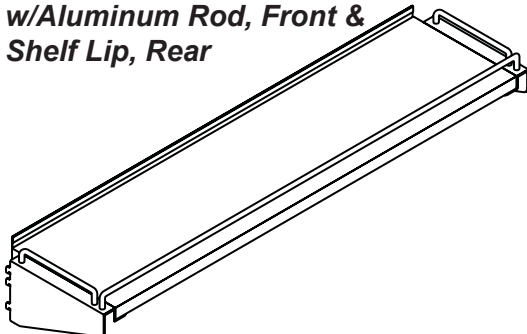

W/ALUMINUM ROD, FRONT & SHELF LIP, REAR:

Painted

	Unit #	Overall Width
ESP	ISB-1642	42" W
ESP	ISB-1648	48" W
ESP	ISB-1660H* (order 2)	60" W
ESP	ISB-1672H* (order 2)	72" W
ESP	ISB-1684H* (order 2)	84" W
ESP	ISB-1696H* (order 2)	96" W

w/Shelf Lips, Front & Rear

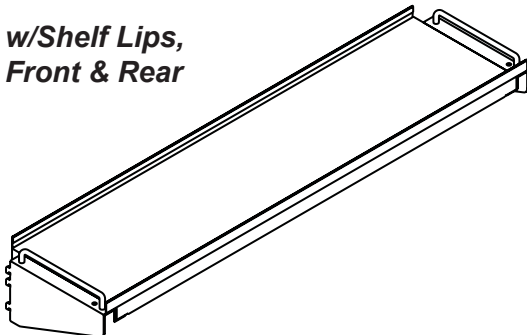

W/SHELF LIPS, FRONT & REAR:

Painted

	Unit #	Overall Width
ESP	ISX-1642	42" W
ESP	ISX-1648	48" W
ESP	ISX-1660H* (order 2)	60" W
ESP	ISX-1672H* (order 2)	72" W
ESP	ISX-1684H* (order 2)	84" W
ESP	ISX-1696H* (order 2)	96" W

Shelves Painted Steel

ENVISION

Shelving Assembly

NO Shelves (Customer Provides)

Painted Steel Brackets

Book End With Accessories

For 12" Deep Shelves

42" W & 48" W are full width

Shelving Assembly for 60" W, 72" W, 84" W & 96" W

Units are Half (H*) Width. Order TWO.

PLAIN

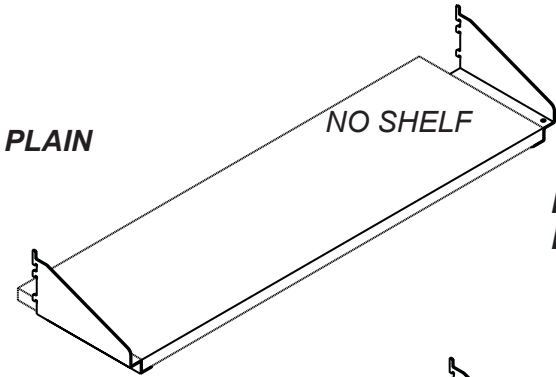

PLAIN: No Shelf

Painted

ESP	Unit #	Overall Width
ESP	BXA-1242	42" W
ESP	BXA-1248	48" W
ESP	BXA-1260H* (order 2)	60" W
ESP	BXA-1272H* (order 2)	72" W
ESP	BXA-1284H* (order 2)	84" W
ESP	BXA-1296H* (order 2)	96" W

w/Aluminum Rod, Front

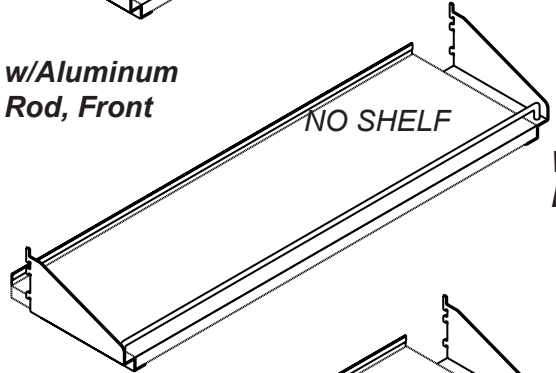

W/ALUMINUM ROD, FRONT: No Shelf

Painted

ESP	Unit #	Overall Width
ESP	BXR-1242	42" W
ESP	BXR-1248	48" W
ESP	BXR-1260H* (order 2)	60" W
ESP	BXR-1272H* (order 2)	72" W
ESP	BXR-1284H* (order 2)	84" W
ESP	BXR-1296H* (order 2)	96" W

w/Shelf Lip Rear

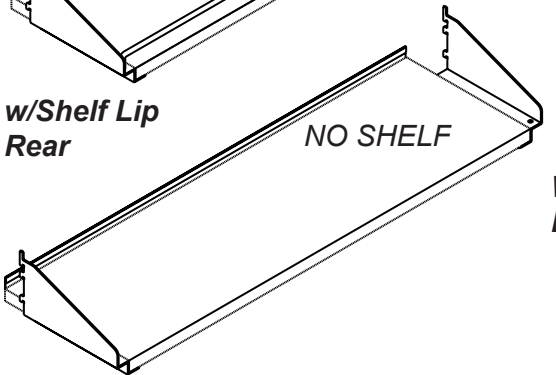

W/SHELF LIP, REAR: No Shelf

Painted or Stainless

ESP	Unit #	Overall Width
ESP	BXL-1242	42" W
ESP	BXL-1248	48" W
ESP	BXL-1260H* (order 2)	60" W
ESP	BXL-1272H* (order 2)	72" W
ESP	BXL-1284H* (order 2)	84" W
ESP	BXL-1296H* (order 2)	96" W

w/Aluminum Rod, Front & Shelf Lip, Rear

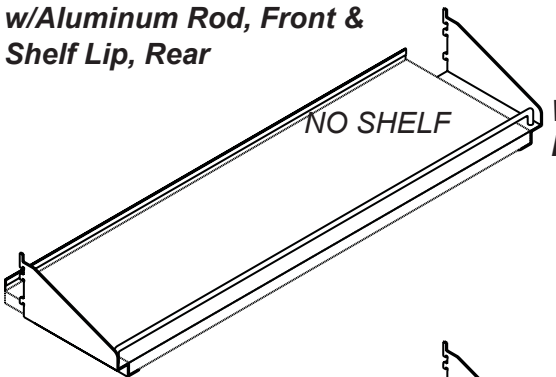

W/ALUMINUM ROD, FRONT & SHELF LIP, REAR: No Shelf

Painted

ESP	Unit #	Overall Width
ESP	BXB-1242	42" W
ESP	BXB-1248	48" W
ESP	BXB-1260H* (order 2)	60" W
ESP	BXB-1272H* (order 2)	72" W
ESP	BXB-1284H* (order 2)	84" W
ESP	BXB-1296H* (order 2)	96" W

w/Shelf Lips, Front & Rear

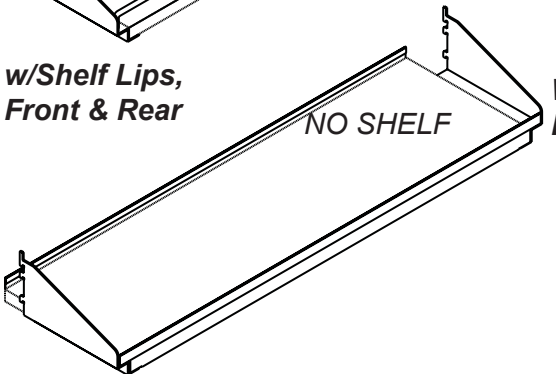

W/SHELF LIPS, FRONT & REAR: No Shelf

Painted

ESP	Unit #	Overall Width
ESP	BXX-1242	42" W
ESP	BXX-1248	48" W
ESP	BXX-1260H* (order 2)	60" W
ESP	BXX-1272H* (order 2)	72" W
ESP	BXX-1284H* (order 2)	84" W
ESP	BXX-1296H* (order 2)	96" W

ENVISION

Shelving Assembly

NO Shelves (Customer Provides)

Painted Steel Brackets

Inverted Bracket With Accessories

For 10" Deep Shelves

42" W & 48" W are full width

Shelving Assembly for 60" W, 72" W, 84" W & 96" W

Units are Half (H*) Width. Order TWO.

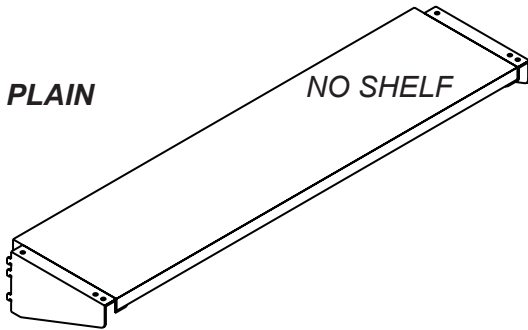

PLAIN

PLAIN: No Shelf

Painted

	Unit #	Overall Width
ESP	IXA-1042	42" W
ESP	IXA-1048	48" W
ESP	IXA-1060H* (order 2)	60" W
ESP	IXA-1072H* (order 2)	72" W
ESP	IXA-1084H* (order 2)	84" W
ESP	IXA-1096H* (order 2)	96" W

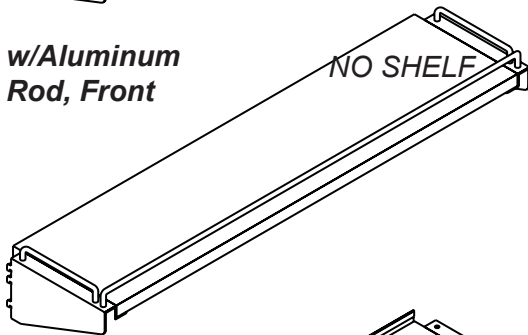

w/Aluminum Rod, Front

W/ALUMINUM ROD, FRONT: No Shelf

Painted

	Unit #	Overall Width
ESP	IXR-1042	42" W
ESP	IXR-1048	48" W
ESP	IXR-1060H* (order 2)	60" W
ESP	IXR-1072H* (order 2)	72" W
ESP	IXR-1084H* (order 2)	84" W
ESP	IXR-1096H* (order 2)	96" W

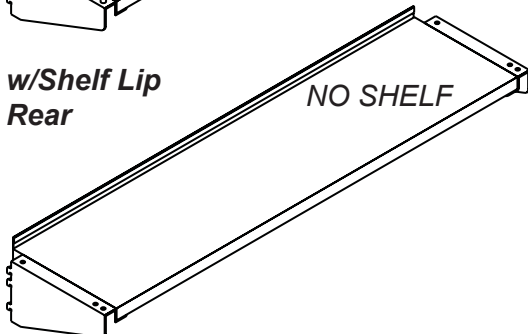

w/Shelf Lip Rear

W/SHELF LIP, REAR: No Shelf

Painted

	Unit #	Overall Width
ESP	IXL-1042	42" W
ESP	IXL-1048	48" W
ESP	IXL-1060H* (order 2)	60" W
ESP	IXL-1072H* (order 2)	72" W
ESP	IXL-1084H* (order 2)	84" W
ESP	IXL-1096H* (order 2)	96" W

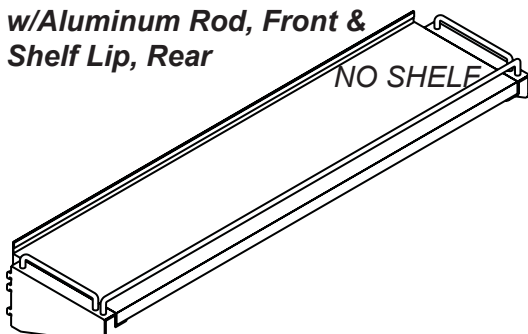

w/Aluminum Rod, Front & Shelf Lip, Rear

W/ALUMINUM ROD, FRONT & SHELF LIP, REAR: No Shelf

Painted

	Unit #	Overall Width
ESP	IXB-1042	42" W
ESP	IXB-1048	48" W
ESP	IXB-1060H* (order 2)	60" W
ESP	IXB-1072H* (order 2)	72" W
ESP	IXB-1084H* (order 2)	84" W
ESP	IXB-1096H* (order 2)	96" W

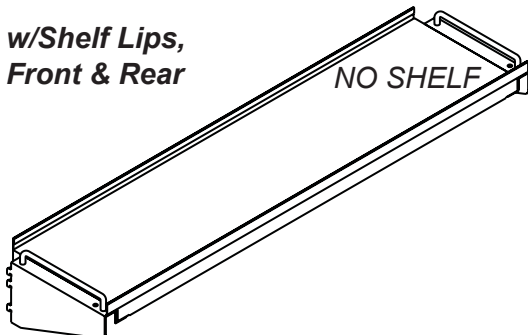

w/Shelf Lips, Front & Rear

W/SHELF LIPS, FRONT & REAR: No Shelf

Painted

	Unit #	Overall Width
ESP	IXX-1042	42" W
ESP	IXX-1048	48" W
ESP	IXX-1060H* (order 2)	60" W
ESP	IXX-1072H* (order 2)	72" W
ESP	IXX-1084H* (order 2)	84" W
ESP	IXX-1096H* (order 2)	96" W

NO Shelves Provided

ENVISION

Shelving Assembly

NO Shelves (Customer Provides)

Painted Steel Brackets

Book End With Accessories

For 15" Deep Shelves

42" W & 48" W are full width

Shelving Assembly for 60" W, 72" W, 84" W & 96" W

Units are Half (H*) Width. Order TWO.

PLAIN

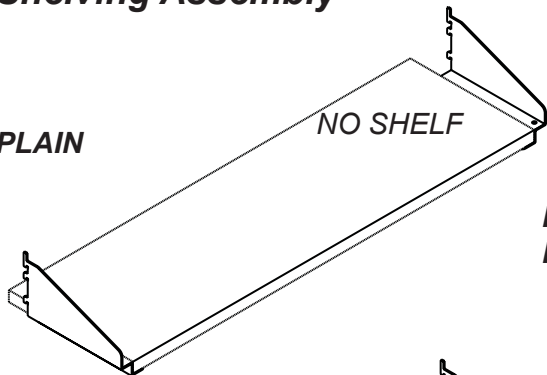

PLAIN: No Shelf

Painted

ESP	Unit #	Overall Width
ESP	BXA-1542	42" W
ESP	BXA-1548	48" W
ESP	BXA-1560H* (order 2)	60" W
ESP	BXA-1572H* (order 2)	72" W
ESP	BXA-1584H* (order 2)	84" W
ESP	BXA-1596H* (order 2)	96" W

w/Aluminum Rod, Front

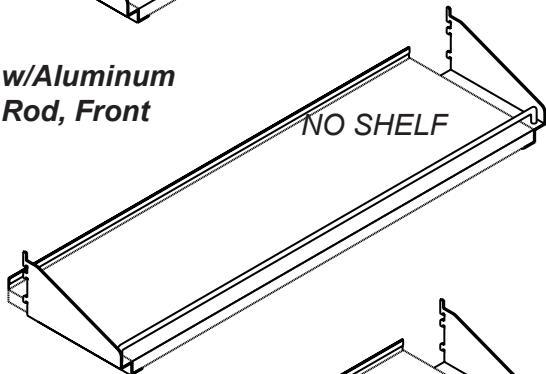

W/ALUMINUM ROD, FRONT: No Shelf

Painted

ESP	Unit #	Overall Width
ESP	BXR-1542	42" W
ESP	BXR-1548	48" W
ESP	BXR-1560H* (order 2)	60" W
ESP	BXR-1572H* (order 2)	72" W
ESP	BXR-1584H* (order 2)	84" W
ESP	BXR-1596H* (order 2)	96" W

w/Shelf Lip Rear

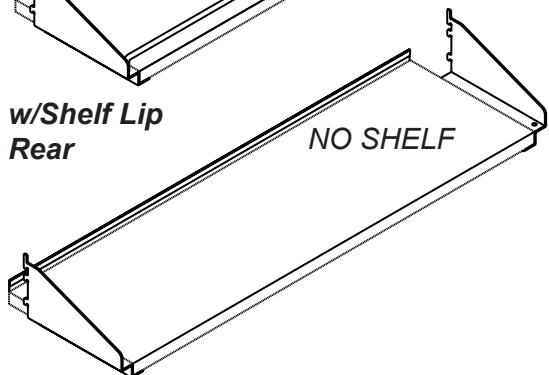

W/SHELF LIP, REAR: No Shelf

Painted

ESP	Unit #	Overall Width
ESP	BXL-1542	42" W
ESP	BXL-1548	48" W
ESP	BXL-1560H* (order 2)	60" W
ESP	BXL-1572H* (order 2)	72" W
ESP	BXL-1584H* (order 2)	84" W
ESP	BXL-1596H* (order 2)	96" W

w/Aluminum Rod, Front & Shelf Lip, Rear

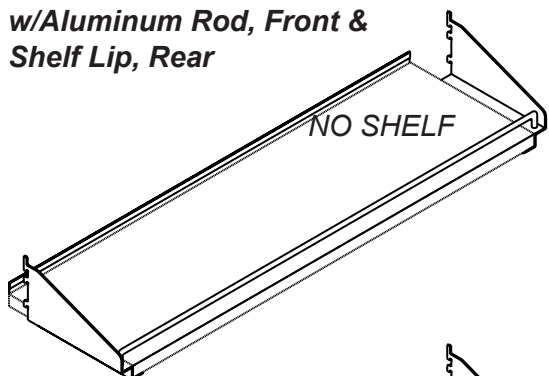

W/ALUMINUM ROD, FRONT & SHELF LIP, REAR: No Shelf

Painted

ESP	Unit #	Overall Width
ESP	BXB-1542	42" W
ESP	BXB-1548	48" W
ESP	BXB-1560H* (order 2)	60" W
ESP	BXB-1572H* (order 2)	72" W
ESP	BXB-1584H* (order 2)	84" W
ESP	BXB-1596H* (order 2)	96" W

w/Shelf Lips, Front & Rear

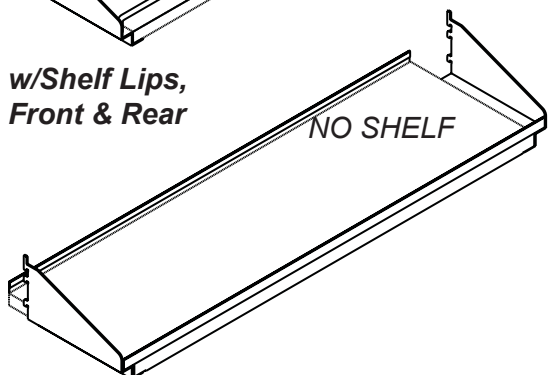

W/SHELF LIPS, FRONT & REAR: No Shelf

Painted

ESP	Unit #	Overall Width
ESP	BXX-1542	42" W
ESP	BXX-1548	48" W
ESP	BXX-1560H* (order 2)	60" W
ESP	BXX-1572H* (order 2)	72" W
ESP	BXX-1584H* (order 2)	84" W
ESP	BXX-1596H* (order 2)	96" W

ENVISION

Shelving Assembly

NO Shelves (Customer Provides) Painted Steel Brackets

Book End With Accessories

For 13" Deep Shelves

42" W & 48" W are full width

Shelving Assembly for 60" W, 72" W, 84" W & 96" W

Units are Half (H*) Width. Order TWO.

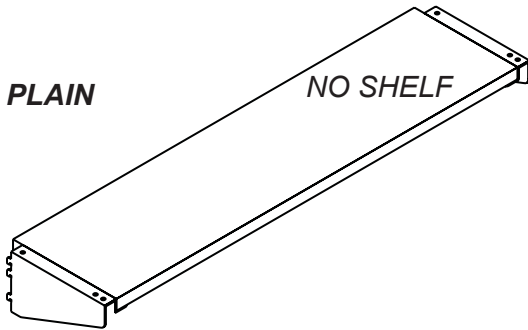

PLAIN: No Shelf

Painted	Unit #	Overall Width
ESP	IXA-1342	42" W
ESP	IXA-1348	48" W
ESP	IXA-1360H* (order 2)	60" W
ESP	IXA-1372H* (order 2)	72" W
ESP	IXA-1384H* (order 2)	84" W
ESP	IXA-1396H* (order 2)	96" W

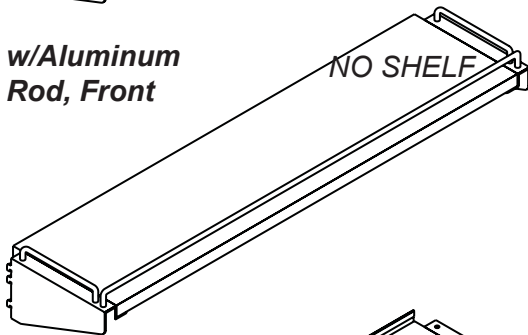

W/ALUMINUM ROD, FRONT: No Shelf

Painted	Unit #	Overall Width
ESP	IXR-1342	42" W
ESP	IXR-1348	48" W
ESP	IXR-1360H* (order 2)	60" W
ESP	IXR-1372H* (order 2)	72" W
ESP	IXR-1384H* (order 2)	84" W
ESP	IXR-1396H* (order 2)	96" W

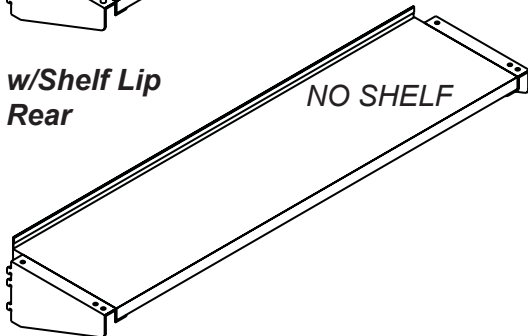

W/SHELF LIP, REAR: No Shelf

Painted	Unit #	Overall Width
ESP	IXL-1342	42" W
ESP	IXL-1348	48" W
ESP	IXL-1360H* (order 2)	60" W
ESP	IXL-1372H* (order 2)	72" W
ESP	IXL-1384H* (order 2)	84" W
ESP	IXL-1396H* (order 2)	96" W

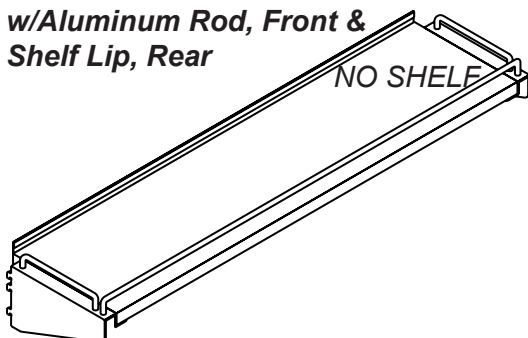

W/ALUMINUM ROD, FRONT & SHELF LIP, REAR: No Shelf

Painted	Unit #	Overall Width
ESP	IXB-1342	42" W
ESP	IXB-1348	48" W
ESP	IXB-1360H* (order 2)	60" W
ESP	IXB-1372H* (order 2)	72" W
ESP	IXB-1384H* (order 2)	84" W
ESP	IXB-1396H* (order 2)	96" W

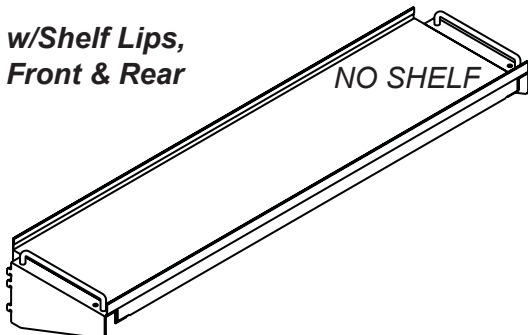

W/SHELF LIPS, FRONT & REAR: No Shelf

Painted	Unit #	Overall Width
ESP	IXX-1342	42" W
ESP	IXX-1348	48" W
ESP	IXX-1360H* (order 2)	60" W
ESP	IXX-1372H* (order 2)	72" W
ESP	IXX-1384H* (order 2)	84" W
ESP	IXX-1396H* (order 2)	96" W

NO Shelves Provided

ENVISION

Shelving Assembly

NO Shelves (Customer Provides)

Painted Steel Brackets

Book End With Accessories

For 18" Deep Shelves

42" W & 48" W are full width

Shelving Assembly for 60" W, 72" W, 84" W & 96" W

Units are Half (H*) Width. Order TWO.

PLAIN

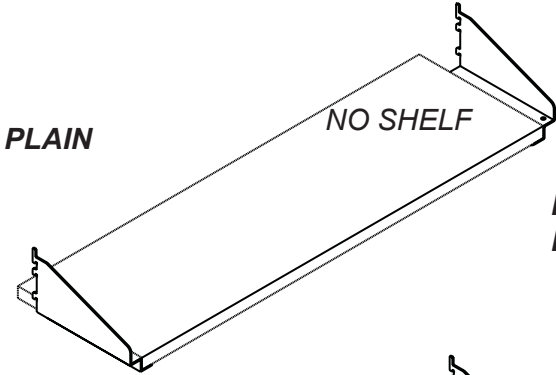

PLAIN: No Shelf

Painted

	Unit #	Overall Width
ESP	BXA-1842	42" W
ESP	BXA-1848	48" W
ESP	BXA-1860H* (order 2)	60" W
ESP	BXA-1872H* (order 2)	72" W
ESP	BXA-1884H* (order 2)	84" W
ESP	BXA-1896H* (order 2)	96" W

w/Aluminum Rod, Front

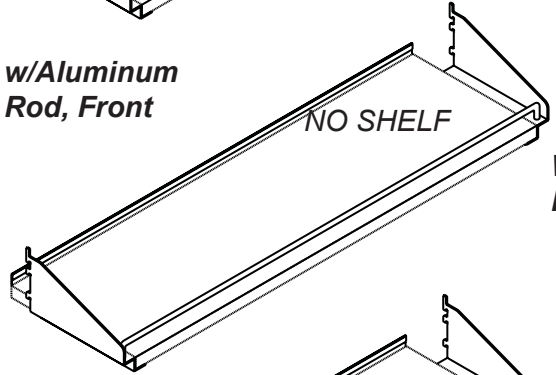

W/ALUMINUM ROD, FRONT: No Shelf

Painted

	Unit #	Overall Width
ESP	BXR-1842	42" W
ESP	BXR-1848	48" W
ESP	BXR-1860H* (order 2)	60" W
ESP	BXR-1872H* (order 2)	72" W
ESP	BXR-1884H* (order 2)	84" W
ESP	BXR-1896H* (order 2)	96" W

w/Shelf Lip Rear

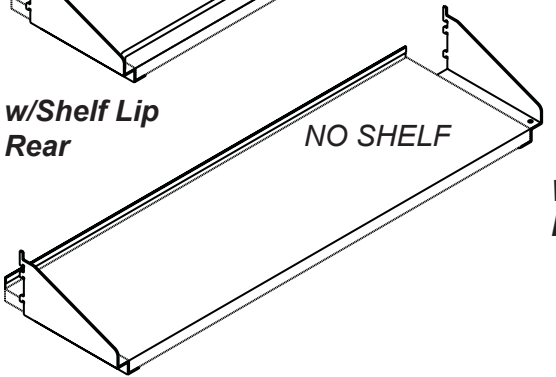

W/SHELF LIP, REAR: No Shelf

Painted

	Unit #	Overall Width
ESP	BXL-1842	42" W
ESP	BXL-1848	48" W
ESP	BXL-1860H* (order 2)	60" W
ESP	BXL-1872H* (order 2)	72" W
ESP	BXL-1884H* (order 2)	84" W
ESP	BXL-1896H* (order 2)	96" W

w/Aluminum Rod, Front & Shelf Lip, Rear

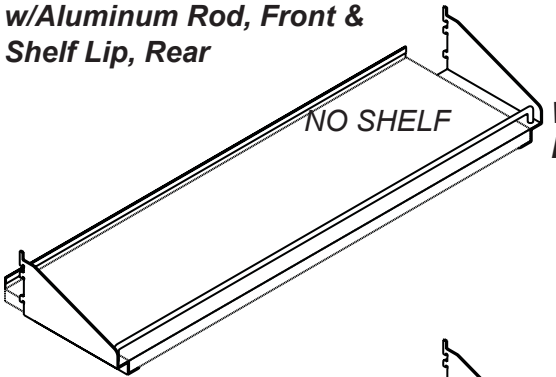

W/ALUMINUM ROD, FRONT & SHELF LIP, REAR: No Shelf

Painted

	Unit #	Overall Width
ESP	BXB-1842	42" W
ESP	BXB-1848	48" W
ESP	BXB-1860H* (order 2)	60" W
ESP	BXB-1872H* (order 2)	72" W
ESP	BXB-1884H* (order 2)	84" W
ESP	BXB-1896H* (order 2)	96" W

w/Shelf Lips, Front & Rear

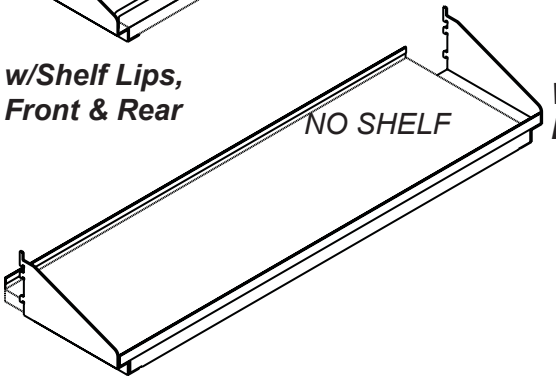

W/SHELF LIPS, FRONT & REAR: No Shelf

Painted

	Unit #	Overall Width
ESP	BXX-1842	42" W
ESP	BXX-1848	48" W
ESP	BXX-1860H* (order 2)	60" W
ESP	BXX-1872H* (order 2)	72" W
ESP	BXX-1884H* (order 2)	84" W
ESP	BXX-1896H* (order 2)	96" W

ENVISION

Shelving Assembly

NO Shelves (Customer Provides) Painted Steel Brackets

Book End With Accessories

For 16" Deep Shelves

42" W & 48" W are full width

Shelving Assembly for 60" W, 72" W, 84" W & 96" W

Units are Half (H*) Width. Order TWO.

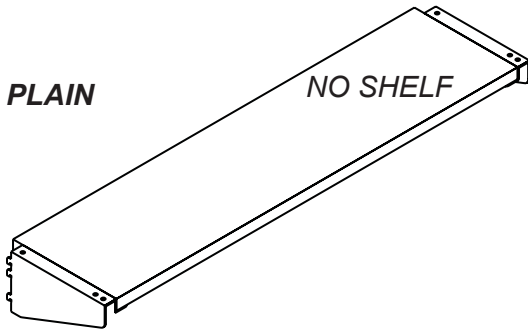

PLAIN

PLAIN: No Shelf

Painted	Unit #	Overall Width
ESP	IXA-1642	42" W
ESP	IXA-1648	48" W
ESP	IXA-1660H* (order 2)	60" W
ESP	IXA-1672H* (order 2)	72" W
ESP	IXA-1684H* (order 2)	84" W
ESP	IXA-1696H* (order 2)	96" W

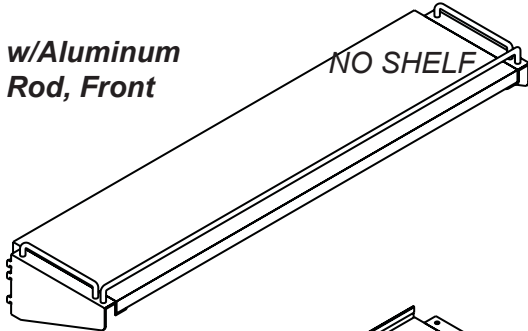

w/Aluminum Rod, Front

W/ALUMINUM ROD, FRONT: No Shelf

Painted	Unit #	Overall Width
ESP	IXR-1642	42" W
ESP	IXR-1648	48" W
ESP	IXR-1660H* (order 2)	60" W
ESP	IXR-1672H* (order 2)	72" W
ESP	IXR-1684H* (order 2)	84" W
ESP	IXR-1696H* (order 2)	96" W

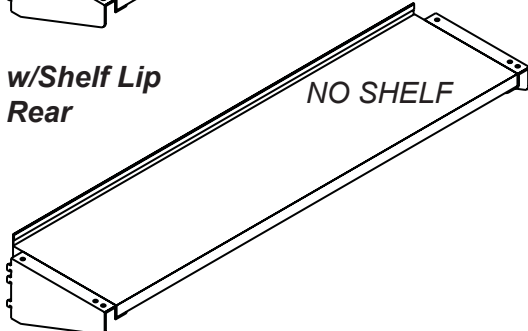

w/Shelf Lip Rear

W/SHELF LIP, REAR: No Shelf

Painted	Unit #	Overall Width
ESP	IXL-1642	42" W
ESP	IXL-1648	48" W
ESP	IXL-1660H* (order 2)	60" W
ESP	IXL-1672H* (order 2)	72" W
ESP	IXL-1684H* (order 2)	84" W
ESP	IXL-1696H* (order 2)	96" W

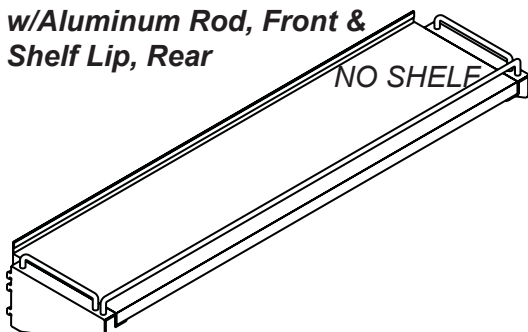

w/Aluminum Rod, Front & Shelf Lip, Rear

W/ALUMINUM ROD, FRONT & SHELF LIP, REAR: No Shelf

Painted	Unit #	Overall Width
ESP	IXB-1642	42" W
ESP	IXB-1648	48" W
ESP	IXB-1660H* (order 2)	60" W
ESP	IXB-1672H* (order 2)	72" W
ESP	IXB-1684H* (order 2)	84" W
ESP	IXB-1696H* (order 2)	96" W

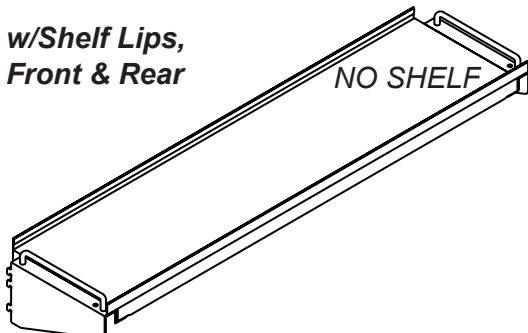

w/Shelf Lips, Front & Rear

W/SHELF LIPS, FRONT & REAR: No Shelf

Painted	Unit #	Overall Width
ESP	IXX-1642	42" W
ESP	IXX-1648	48" W
ESP	IXX-1660H* (order 2)	60" W
ESP	IXX-1672H* (order 2)	72" W
ESP	IXX-1684H* (order 2)	84" W
ESP	IXX-1696H* (order 2)	96" W

NO Shelves Provided

**Wire Management Tray &
Mobile Cabinet Stop
22" D Mobile Cabinet**

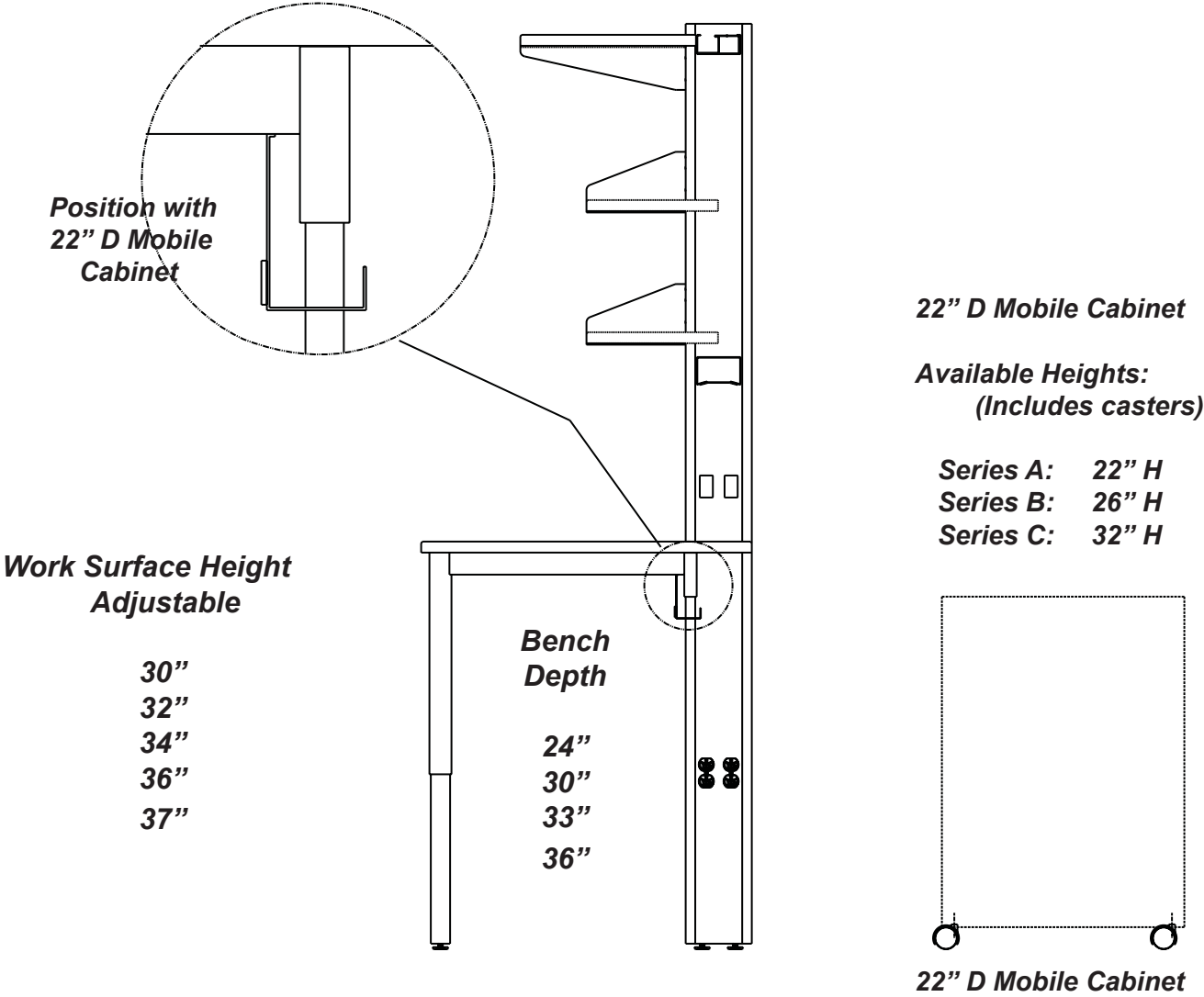

Wire Management Tray & 22"D Mobile Cabinet Stop

Bench Width	Unit #
42" W	EMPJ-42
48" W	EMPJ-48
60" W	EMPJ-60
72" W	EMPJ-72
84" W	EMPJ-84
96" W	EMPJ-96

**Wire Management Tray &
Mobile Cabinet Stop
22-7/8" D Mobile Cabinet**

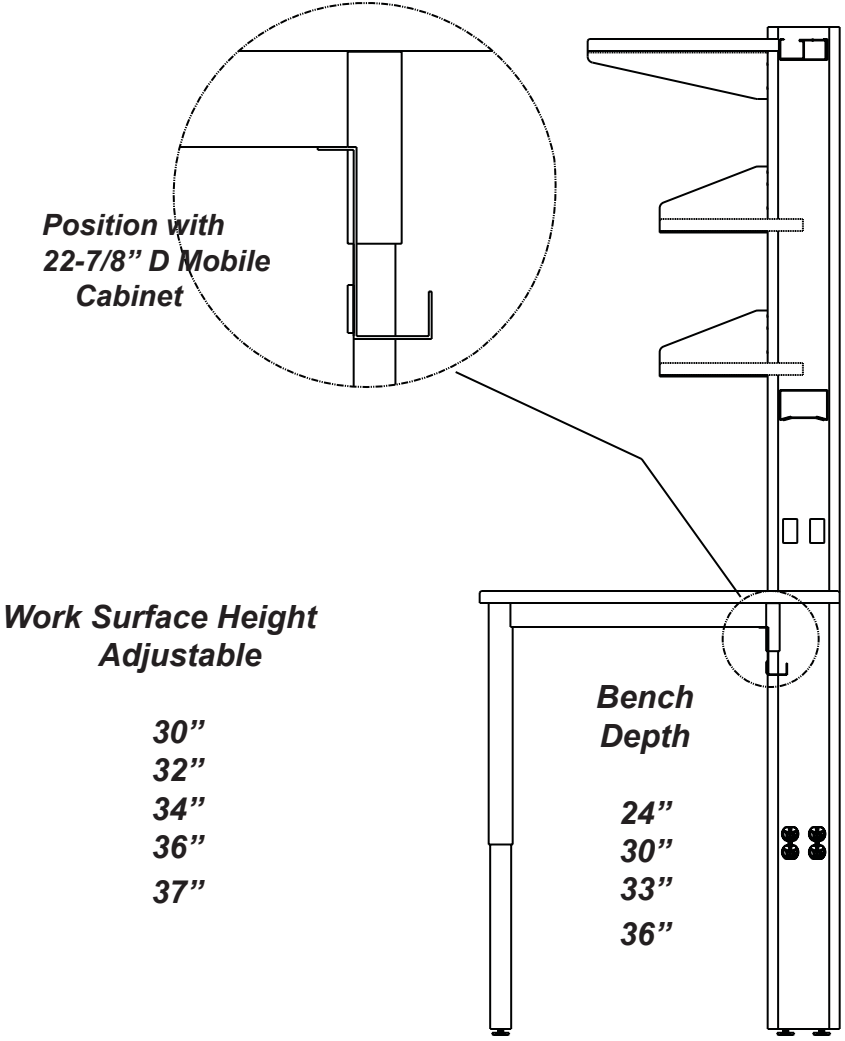

22-7/8" D Mobile Cabinet

**Available Heights:
(Includes casters)**

- Series A: 22" H**
- Series B: 26" H**
- Series C: 32" H**

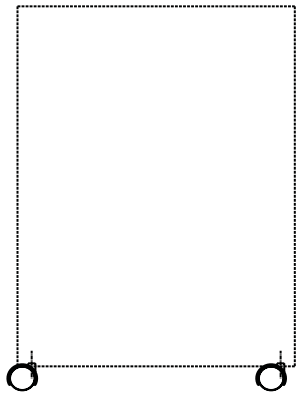

22-7/8" D Mobile Cabinet

Wire Management Tray & 22-7/8"D Mobile Cabinet Stop

Bench Width	Unit #
42" W	EMPX-42
48" W	EMPX-48
60" W	EMPX-60
72" W	EMPX-72
84" W	EMPX-84
96" W	EMPX-96

**Wire Management
Mobile Cabinet Stop**

