



# Technical Bulletin

178 Blackstone Avenue Jamestown NY 14701

[www.jamestown.com](http://www.jamestown.com)

716.665.5313

Date: August 15, 2011

No.: 016

To: Customer Service, Engineering, Estimating, Operations, Sales, Valued JMP Dealers

Subject: FlexCore, New Product Introduction – **Mobile Cart, Heavy Duty, 36”H, with Leveling Casters**

JMP is pleased to announce the addition of the **Mobile Cart, Heavy Duty, 36”H, with Leveling Casters** to the FlexCore Product Line:

- **Mobile Cart, Heavy Duty, 36”H, with Leveling Casters** are generally used in place of a 78” Full Height Mobile Cart when there are no shelves or other features required above the work surface
- Each **Mobile Cart, Heavy Duty, 36”H, with Leveling Casters** includes four heavy duty Leveling Casters (Zambus® Foot Master®, or equivalent), all of which when fully extended provide a level of vibration dampening
- NOTE: No option exists presently to extend the height of the uprights to 78” Full Height, however that option is planned for a future release, date TBA
- Please refer to JMP Flex Laboratory System specification for all other information regarding the design and application of this **Mobile Cart, Heavy Duty, 36”H, with Leveling Casters**

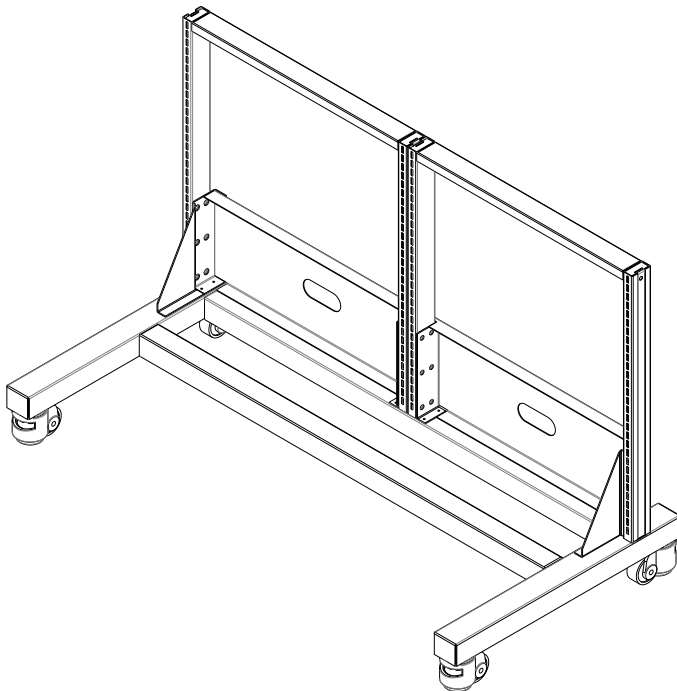

Mobile Cart,  
Heavy Duty,  
36”H,  
With Leveling Casters

<u>Unit #</u>	<u>W</u>	<u>H</u>
PMC2436-HDZ	24"	36"
PMC3036-HDZ	30"	36"
PMC3636-HDZ	36"	36"
PMC4236-HDZ	42"	36"
PMC4836-HDZ	48"	36"
PMC5436-HDZ	54"	36"
PMC6036-HDZ	60"	36"
PMC6636-HDZ	66"	36"
PMC7236-HDZ	72"	36"

Contact JMP for more information.

FlexCore Engineering  
Jamestown Metal Products, LLC