



ATTACHING BENCH TOP 6", 8-3/4" & 12" CORES TO WORK SURFACE

Tools Required:

- Socket set with 9/16" socket
- 9/16" Combination wrench
- Philips Screw Driver No. 2 & 3 tips
- Drill and 7/16" diameter drill bit
- Hammer

Note 1: To finish off one end of a 6" & 8-3/4" Bench Top Core one end cover is required, for a 12" Bench Top Core 2 end covers are required per core per end. End Covers are ordered separately from the bench top core products.

Note 2: Illustrations below of the three core styles show the end covers attached.

Note 3: The assembly process is very similar for all three styles of Bench Top Cores. The 6" Bench Top Core is shown and described in the instruction.

Note 4: Screws for attaching the Bench Top Wall Cores to the wall are provided by the installer.

Hardware Include in PBTC0875-KIT included with each 8-3/4" Bench Top Wall Core:

- 4 HHCS, 3/8"-16 x 3/4", Grade 5
- 2 HHCS, 3/8"-16 x 2-1/4", grade 5
- 1 HHCS, 3/8"-16 x 3-1/2", Grade 5
- 3 Nuts, 3/8"-16
- 7 Washer, Lock 3/8"

- 2 Cover Clip
- 2 Covers
- 2 Bench Top Upright Support Weldment
- 2 Base
- 4 PHSMS #10 x 1/2"

Hardware Include in PBTC12-KIT included with each 12" Bench Top Core:

- 8 HHCS, 3/8"-16 x 3/4", Grade 5
- 4 HHCS, 3/8"-16 x 2-1/4", grade 5
- 2 HHCS, 3/8"-16 x 3-1/2", Grade 5
- 6 Nuts, 3/8"-16
- 14 Washer, Lock 3/8"

- 4 Cover Clip
- 4 Covers
- 2 Bench Top Upright Support Weldment
- 2 Base
- 8 PHSMS #10 x 1/2"

Hardware Include in PUEF-KIT B included with each end cover assembly for 8-3/4" & 12" Bench Top Core:

- 2 HHCS, 3/8"-16 x 1-3/4", grade 5
- 2 Washer, Lock 3/8"
- 2 Nuts, 3/8"-16
- 1 End Cover Clip, 3-1/4" upright

Hardware Include in PBTC06-KIT included with each 6" Bench Top Core:

- 8 HHCS, 3/8"-16 x 3/4", Grade 5
- 4 HHCS, 3/8"-16 x 2-1/4", grade 5
- 2 HHCS, 3/8"-16 x 3-1/2", Grade 5
- 6 Nuts, 3/8"-16
- 14 Washer, Lock 3/8"
- 2 Cover Clip
- 2 Covers
- 2 Bench Top Upright Support Weldment
- 2 Base
- 4 PHSMS #10 x 1/2"

Hardware Include in PUEF-KIT C included with each end cover assembly for 6" Bench Top Core:

- 2 HHCS, 3/8"-16 x 1-3/4", grade 5
- 2 Washer, Lock 3/8"
- 4 Nuts, 3/8"-16
- 1 End Cover Clip, 6" upright

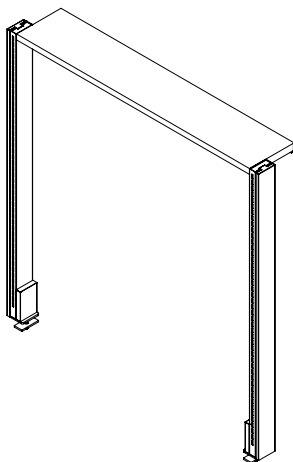

8-3/4" Wall
Bench Top Core

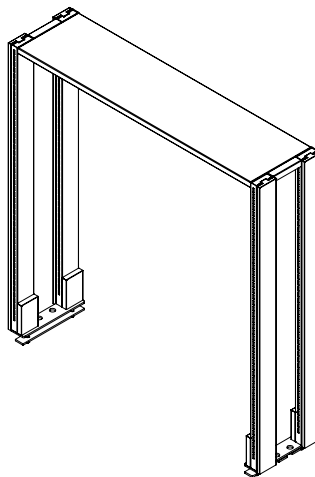

12" Bench Top Core

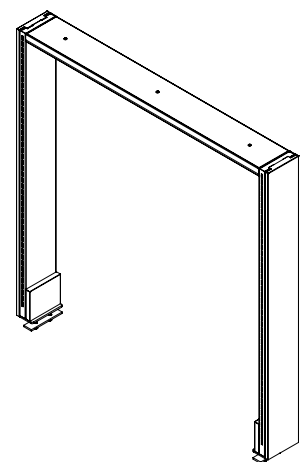

6" Bench Top Core

**ATTACHING BENCH TOP 6", 8-3/4" & 12" CORES TO WORK SURFACE**

...continued from previous page

1. Layout the appropriate core hole pattern & drill the holes through the work surface (see next page for details).
2. Attach the bench top upright weldments (A) with 3/8"-16 x 2-1/4" HHCS (B) through the weldment (A), work surface (not shown), base (C) (located under the work surface) with 3/8" lock washers (D) and nuts (E), leaving hardware finger tight.
3. Position the uprights (F) on a flat surface and attached the top rail (G) to the uprights (F) with the PHSMS #10 screws (H).
4. Carefully raise the assembly up and slide the uprights (F) down over the bench top upright weldments (A) and insert the 3/8"-16 x 3/4" HHCS (J) and lock washers (K) through the cover clip (L) (be careful of the cover clip orientation, the offset bends should be approximately 1/16" off of the upright surface to allow for the cover (M) to slide down).
5. If the Bench Top Cores are positioned and connected end to end, insert the 3/8"-16 x 3-1/2" HHCS (not shown) through the top of the uprights and secure with the 3/8" lock washer and nut (not shown).
6. If this is a 8-3/4" Bench Top Wall Core attached top rail to the wall with screws (screws are provide by the installer).
7. Tighten all hardware securely.
8. If this is 6" Bench Top Core, attach cover (N) with the PHSMS #10 screws (P)
9. If end covers (R) are required at the end of the assembly, insert the 3/8"-16 x 1-3/4" HHCS (S) through the end cover clip (T) and upright, attaching with 3/8" lock washer and nut as shown. Attached the end covers (R) be inserting the tabs (U) into slots (V) and slide down the end cover engaging flanges (W) between end cover clip (T) and upright (F).
10. Attach the covers (M) by siding the cover down with the cover flanges capture between the upright (F) and cover clip (L).

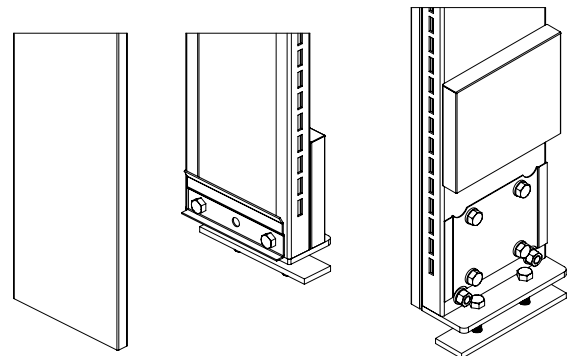
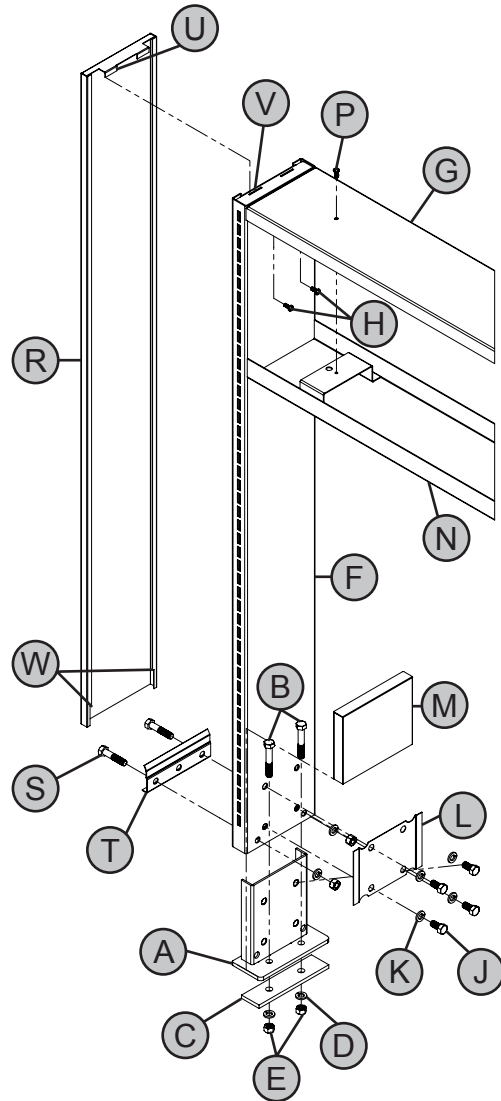

Outside view showing the end cover clip attached

Inside View with cover raised up to show the attaching hardware

continued on next page...



ATTACHING BENCH TOP 6", 8-3/4" & 12" CORES TO WORK SURFACE

...continued from previous page

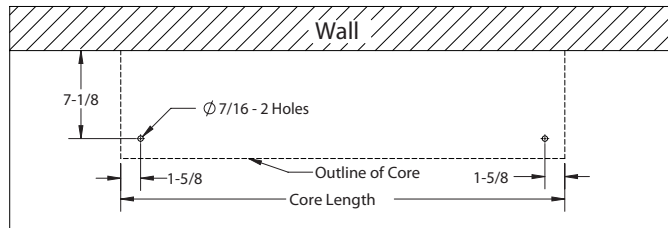
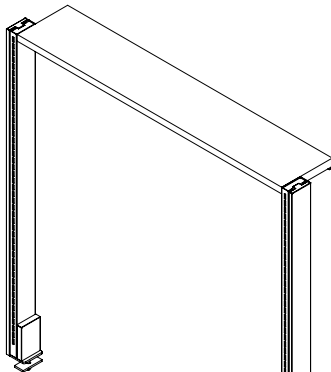

8-3/4" Wall Bench Top Core Hole Mounting Pattern

8-3/4" Wall Bench Top Core

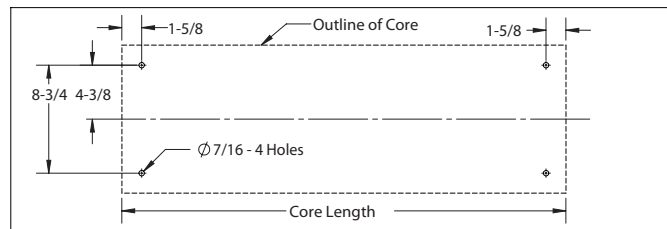
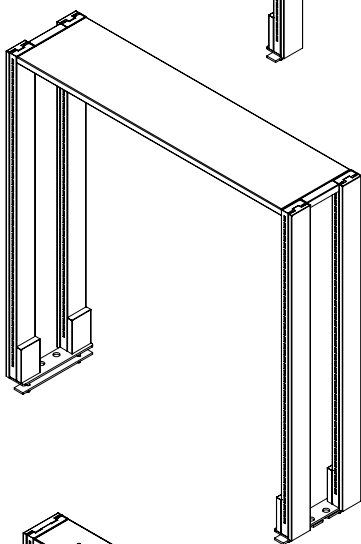

12" Bench Top Core Hole Mounting Pattern

12" Bench Top Core

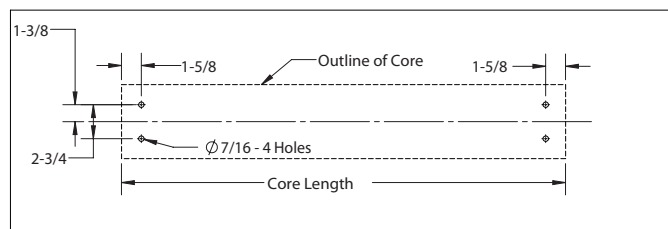
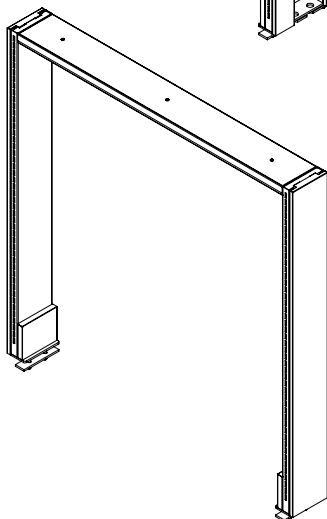

6" Bench Top Core Hole Mounting Pattern

6" Bench Top Core