



FlexCore®

178 Blackstone Avenue, Jamestown NY 14701

www.jamestown.com

716.665.5313

ATTACHING 3-1/4" STANDING HT. CORNER POST, "T" CONFIGURATION TO STANDING HT. CORES OR 1 FULL HT. CORE AND 2 STANDING HT. CORES

Tools Required:

Socket set with 1/2" & 9/16" socket
1/2" & 9/16" Combination wrench

Hardware Included with PSHSHTC0325-Kit included with "T"

Standing Ht Corner Column:

- 3 HHCS, 3/8 -16 x 2-1/4", grade 5
- 3 Washer, Lock 3/8"
- 2 Brackets

Note 1: The lower corner bracket location (C) uses the HHCS hardware that comes with the core to attach the corner bracket.

Note 2: Refer to "Attaching 3-1/4" Core to Floor" for additional details.

1. Remove side closure panels (not shown) and ledge panel covers (A) and bottom rail covers (B), to gain access for installing hardware.
2. Attach the lower (C) and mid (D) corner brackets to the core as shown with the head of the HHCS (E) and lock washer (F) on the inside of the core upright, through the locking angle (only at lower bracket location), upright then into the corner bracket. At the lower bracket location (C) use the HHCS (G) hardware that comes with the core to attach the corner bracket.
3. Locate level and assemble the second 3 1/4" core to the first one repeating step 1.
4. Locate level and assemble the third 3 1/4" core (not shown) to the first one repeating step 1.
5. Attach the cover assembly (H) by inserting the cover tabs at the mid and lower locations into the slots (J) on the corner brackets as shown.
Note: The top of cover assembly (H) will be flush with 1" thick work surface material (P) as shown in the completely assembled view.
6. When the assembly has one full height core, attach the upper cover assembly (K) by inserting the tabs (L) at the top of the cover into the slots (M) at the top of the upright and the tab (N) at the lower end of the cover is inserted between the cover assembly (H) and upright (see completely assembled view).
7. Re-install all side closure panels (not shown), ledge panel covers (A) and bottom rail covers (B).

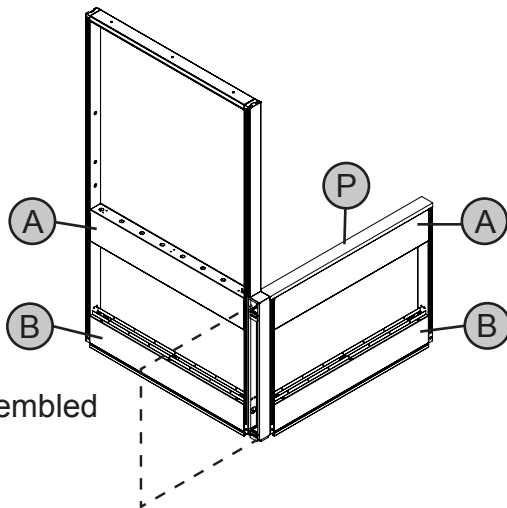
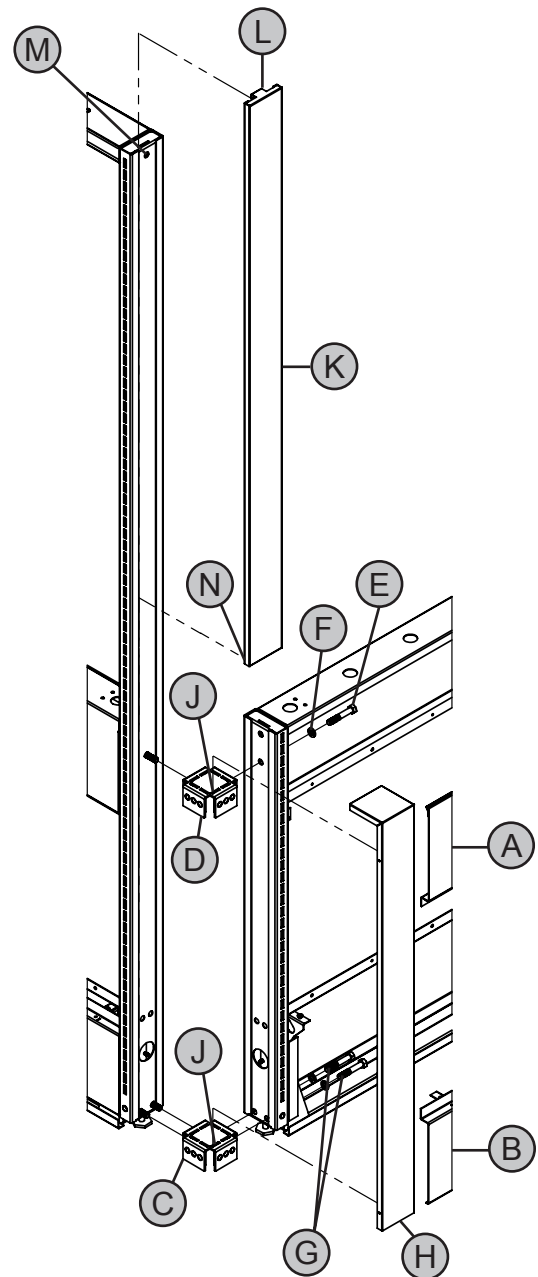

Fully Assembled