



ATTACHING 3-1/4" FULL HT. CORNER POST IN A "L" CONFIGURATION TO FULL HT. CORES

Tools Required:

Socket set with 1/2" & 9/16" socket
1/2" & 9/16" Combination wrench
Phillips Screw Driver No. 2 & 3 tips

Hardware Included with PFHFHLC0325-Kit included with Full Ht Corner Post "L" Configuration:

4 HHCS, 3/8 -16 x 2-1/4", grade 5
4 Washer, Lock 3/8"
4 Nuts, 3/8 -16
3 Brackets

Note 1: The lower bracket location (D) uses the HHCS hardware that comes with the core to attach the corner bracket.

Note 2: Refer to "Attaching 3-1/4" Core to Floor" for additional details

1. Remove side closure panels (not shown), bottom panels (A), ledge panels (B) and cover panel top weldments (C), to gain access for installing hardware.
2. Assembly the lower (D), mid (E) and upper (F) corner brackets to one core as shown with the head of the HHCS (G) on outside through the corner bracket, upright, floor clamp, locking angle (K), lock washer and nut as shown.
3. Locate level and assemble the second 3-1/4" core to the corner brackets, repeating step 1 and making sure the second core is 90 degrees to the first core.
4. Attach cover (H) by inserting the locating tabs at the top, middle and bottom into the slots (J) on the corner brackets.
5. Reinstall the bottom panels (A), ledge panels (B) and cover panel top weldments (C).

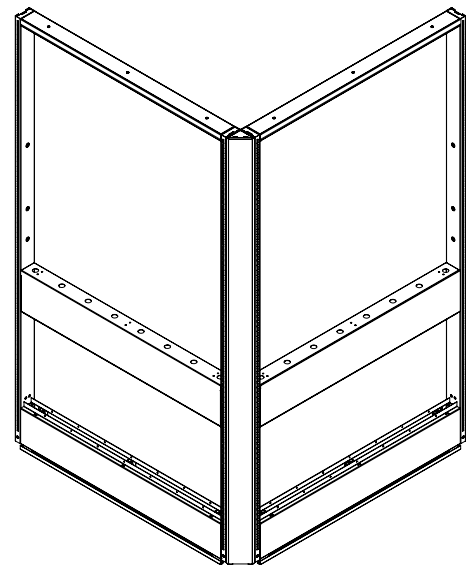
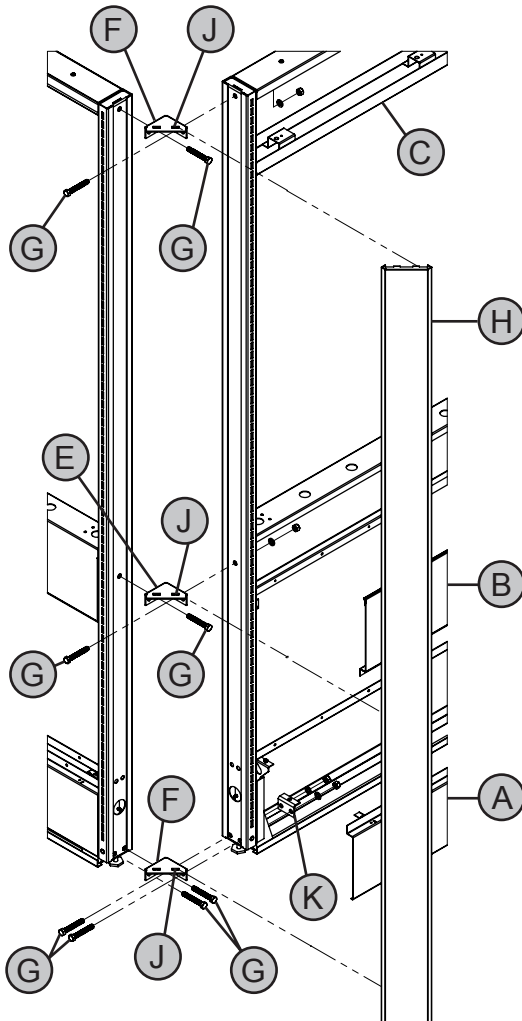

Fully Assembled