



## **ATTACHING 6" FULL HT. CORNER POST, IN "L" CONFIGURATION TO FULL HT. CORES**

### Tools Required:

Socket set with 1/2" & 9/16" socket  
1/2" & 9/16" Combination wrench  
Phillips Screw Driver No. 2 & 3 Tips

### Hardware Included with PFHCP-Kit included with "L" Full Ht Corner Post:

8 HHCS, 3/8 -16 x 2-1/4", grade 5  
8 Washer, Lock 3/8"  
8 Washer, 3/8"  
8 Nut, 3/8-16

**Note 1:** The lower corner bracket location (D) uses the HHCS hardware that comes with the core to attach the corner bracket.

**Note 2:** Refer to "Attaching 6" Core to Floor" for additional details

1. Remove side closure panels (not shown) and ledge panel covers (A), bottom base covers (B) and upper covers (C).
2. Attach the lower (D), mid (E) and upper (F) corner brackets to the core as shown with the head of the HHCS (G) and flat washer (H) and corner brackets (D, E & F) on the outside of the core upright, through the upright, locking angle (only at lower bracket location), lock washer and nut on the inside of the core. At the lower bracket location (D) use the HHCS hardware (K) that comes with the core to attach the corner bracket (See Detail A).
3. Locate level and assemble the second 6" core to the first one repeating step 1 & 2 and attach to the floor.
4. Attach the cover assembly (J) by inserting the cover tabs at the upper, mid and lower locations into the slots (K) on the corner brackets as shown.
5. Re-install ledge panel covers (A), bottom base covers (B), upper covers (C) and all side closure panels (not shown).

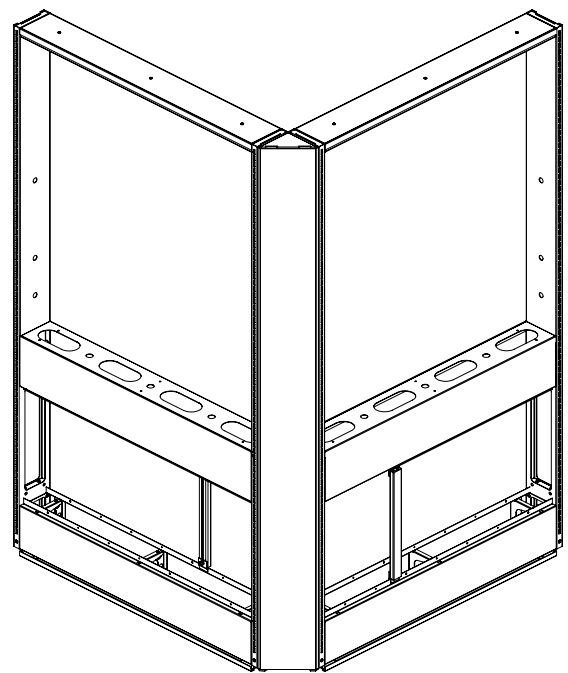
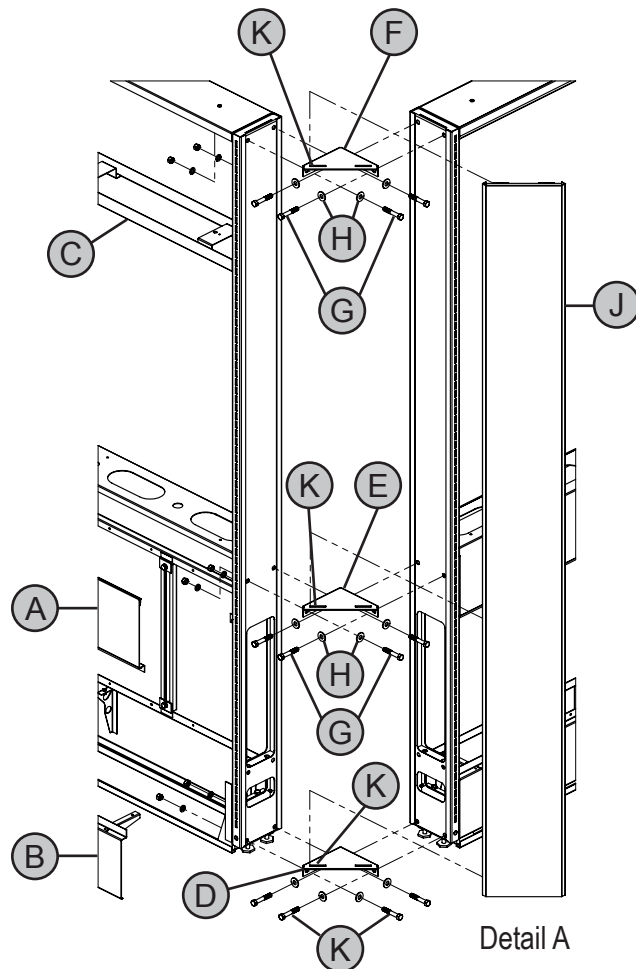

Fully Assembled