



ATTACHING ISLAND CORE TO FLOOR

Tools Required

1/2" Hammer Drill
Masonry Drill Bit - 12" long minimum and diameter to fit floor anchor
Socket Set with 1/2" & 9/16" Socket
1/2" & 9/16" Combination Wrench
Hammer

Hardware Included in PLCH12-KIT A Included with Core:

12 Nuts, 5/16 -18
8 Nuts, 3/8 -16
4 HHCS, 3/8 -16 x 2-1/2", grade 5
4 HHCS, 5/16 -18 x 3-1/2", grade 5
4 Floor Clamp Bolt Angles
2 Floor Clamps
8 Washers, 3/8"
12 Plug Buttons, .75" diameter, black
4 Spacers

Note: Floor anchors are supplied by the installer. All floor anchors must be installed in order to achieve the maximum load ratings.

1. Determine the location of the island core assemblies and snap chalk line for center line of cores.
2. Determine the highest floor elevation point on the floor for the core assembly. Note: All cores within this assembly will be leveled to this point with a 1" space (A) between the bottom of the core and high point elevation location. This space is required for accessibility to core levelers and installation of the base molding support angle.
3. Place the first core in position and attached the floor clamps (B) to the core with the head of the HHCS 3/8-16 x 2-1/2", grade 5 bolt (C), washer (D), spacer (E), on the outside of the core upright, through the upright with floor clamp (B), locking angle (F), lock washer (G) and nut (H) on the inside leaving the hardware loose. The center anchor hole (J) must aligned with the snapped chalk line, level core and tighten hardware.

Note 1: If this is the end of an island assembly and end covers are being installed, refer to section "Attaching End Covers to Island Core" before installing HHCS 3/8" hardware.

Note 2: If connecting to another core refer to section "Connecting Island Core End to End", different length HHCS are required.

4. Using the floor clamp as template drill hole through the center hole (J) first, install anchor and before tightening insert the base molding angle (K) between the floor clamp and floor, aligning the front vertical surface of the angle with the front face of the core. Tighten center anchor, drill and install the remaining anchors (L).
5. Install the vertical HHCS, 5/16-18 x 3" (M) and locking nuts (N) through the top of the floor clamp to the locking angles (F) to lock the vertical movement.
6. Install the plug buttons into the .75" holes in the upright above the work surface.

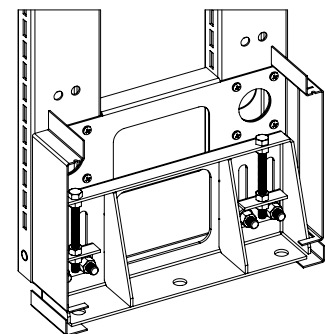
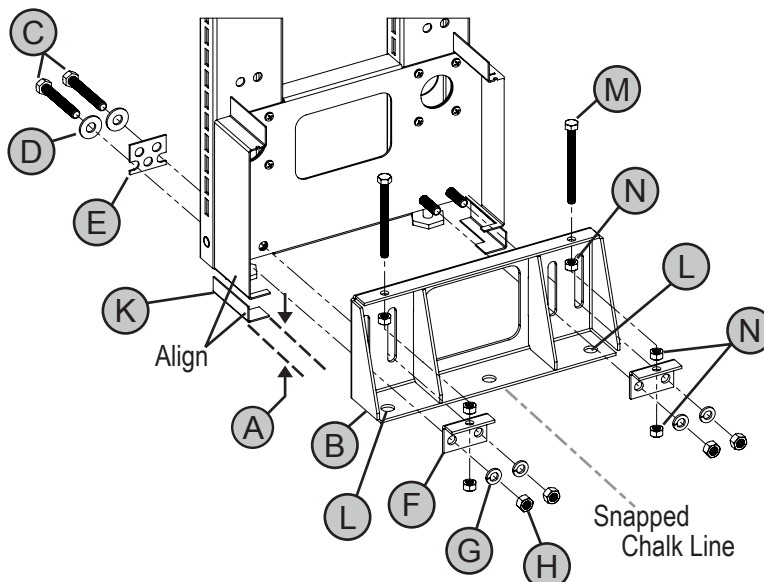

Fully Assembled